

USING SYSTEM DYNAMICS TO MODEL A UNIVERSITY LIBRARY SYSTEM

David A. Lopez
 Graduate School of Business
 University of Washington
 Seattle, WA 98195

ABSTRACT

The application of management science techniques to problems of managing libraries has been a relatively recent development. This paper describes the construction, development, and application of an interactive System Dynamics computer simulation model to a large university library system. Actual experience gained in developing and applying this System Dynamics model is reported. Operational tactics and strategies a library might be considering in its daily operation are simulated and evaluated. Possible improvements to this model are also discussed.

INTRODUCTION

The development and application of the tools of management science within the field of library science has been relatively recent (1)(6)(7). A number of studies have applied such techniques as linear programming, queueing theory and computer simulation modelling (2)(4)(9)(10)(11). One management science methodology that has not been applied is System Dynamics. System Dynamics is a technique for applying control engineering ideas to complex management systems (3)(5)(8) and such models have been used in a wide range of industrial and socio-economic systems.

PROBLEM DESCRIPTION

The problem that is being modelled is a system that has many different service components. Each of these service components has individual goal elements, resource allocation decisions, and effectiveness measures associated with it. The basic goal of an effective library system might be stated in a number of different ways, however, a reasonable definition of the overall system goal might be (6): "To acquire bibliographic materials related to the interests of a particular user population, actual or potential: to organize and display these materials in various ways; and to make them available to users."

To accomplish this basic goal, most libraries are organized in such a manner to have several subsystems to support this main goal. Figure 1 indicates the basic subsystems maintained by many libraries to accomplish their main goal.

<u>Subsystem</u>	<u>Function</u>
Acquisitions System	The major functions of this system are ordering and receiving library materials.
Serial Control System	This system is concerned with control of an informational system that permanently stores serial information for future reference.
Circulation System	The major function of this system is the control of the flow and movement of library materials.
Cataloging System	This is primarily an informational system for classifying books and other library materials and providing the records essential for retrieving them.
Reference System	This system is concerned with retrieval and transfer of information.

Figure 1 BASIC LIBRARY SUBSYSTEMS

Each of the subsystems has associated with that subsystem a number of smaller systems that aid the accomplishment of their major function. For example, within the circulation subsystem, two functional areas are collection storage and access to the collection. These have goal elements and specific resource allocation decisions that a library system can exercise. Associated with these resource allocation decisions are also a number of effectiveness measures that can be quantified and measured to assess the overall impact of a change in policy. Figure 2 indicates how these different subsystems tie together with their goal elements, resource allocation decisions and effectiveness measures.

<u>Functional Area</u>	<u>Goal Elements</u>	<u>Resource Allocation Decisions</u>	<u>Effectiveness Measures</u>
Collection Storage	Collection Arrangement	Reshelving	Reshelving Time
	Collection Location	Shelf Reading	% Documents Missshelved
	Collection Size	Weeding	% Requests in Remote Storage
	Collection Condition	Binding	Storage Cost/Document
Access to Collection	Access to Collection	Remote Storage	% Documents Lost
		Security	% Documents in Correct Location
	Speed of Access	Hours Open	User Access Time
		Loan Policy	Document Retrieval Time
	Ease of Access	Photo Copy Service	% Demands Satisfied
		Access Points	Number of Patrons
Type of Access	Level of Security	Number of User Hours	
	Copyright Policy	% Collection in Open Stacks	
	Type of System		

Figure 2 LIBRARY RESOURCE ALLOCATION FRAMEWORK: CIRCULATION SUBSYSTEM

DATA FOR THE MODEL

The data for the development of this System Dynamics model comes from large public university with a student enrollment of over forty thousand full-time students and two thousand faculty. The university libraries consist of one main graduate library unit, one main undergraduate library unit and eighteen branch libraries who specialize in selected areas. Within this library system there are in excess of four million book volumes, over fifty thousand serial titles, and three million items on microfilm. The annual overall budget is over ten million U.S. dollars. Figure 3 indicates the average monthly circulation figures for these different library units. To simplify this model, only the graduate library will be modelled, since the same process should apply to the other library units as well.

Branch Libraries: 49,268			
Architecture	2,219	Friday Harbor	320
Art	2,689	Geography	905
Business	9,140	Mathematics	940
Chemistry	1,645	Music	3,350
Drama	1,382	Philosophy	1,294
East Asia	2,512	Physics	714
Engineering	4,162	Political Science	2,901
Fish/Ocean	2,947	Social Work	1,814
Forest Resources	1,698	Health Science	8,636
Graduate Library: 27,990			
Undergraduate Library: 15,055			
Total:	92,313		

Figure 3 AVERAGE MONTHLY CIRCULATION UNIVERSITY LIBRARY SYSTEM-ALL UNITS

MODEL DEVELOPMENT

The System Dynamics model boundary has been defined to include the most important elements of the graduate library book circulation system. This consists broadly of a book acquisitions loop, a books borrowed loop, and books returned loop. Figure 4 is an influence diagram which shows the cause and effect relationships between the variables chosen. The following assumptions were made in devising this influence diagram:

- (1) Only the graduate library book circulation system is being modelled.
- (2) No new capacity is to be added to the library system.
- (3) The system is driven by a demand pattern that is closely tied to academic calendar during the year.

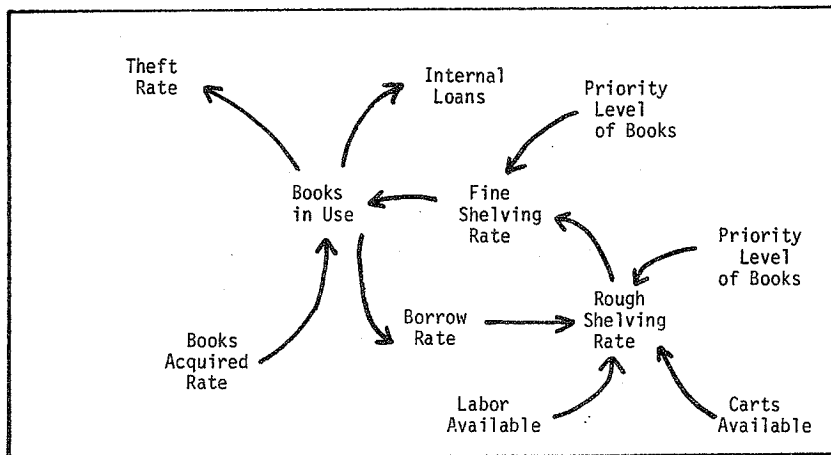

Figure 4 INFLUENCE DIAGRAM GRADUATE LIBRARY CIRCULATION

From the influence diagram in Figure 4, one of the key problems in the operation of this library system becomes clearer. In a number of key locations, books in various stages of being returned to the book shelves are cycled thru the system. Since there is an average of 28,000 books being processed each month, this becomes a rather large problem. This process involves a preliminary sort, a rough sort by the floor the book is to be on, books sorted by carding table, books loaded on small hand trucks, and books finely sorted on the book trucks. The books are finally placed back on their original locations within the library system. Thus, the key operational management decisions involve where labor is to be assigned within the system and the physical resources (carts) that are to be allocated to assist the labor force. The management system used to achieve the overall system goal of smooth and rapid dispersal of materials back to the shelves has been the development of a priority system that places additional resources within the system as backlogs build-up. This priority system has three levels of importance: Priority 1 - critical, Priority 2 - important, Priority 3 - non-critical. These priority levels can be shifted as the needs of the system change over time, usually a month.

FLOW DIAGRAM

From the Influence Diagram depicted in Figure 4, a detailed flow chart was developed that included some of the specific characteristics of this circulation system. This flow chart is shown in Figure 5. The various levels within the model are books in different stages of being sorted. One notes quickly the importance of the priority rules established in the operating system. Libraries can best be characterized as organizations that are extremely labor intensive. Many practical day-by-day decisions involve where and how the labor available is to be allocated to trying to achieve the overall goal of efficiency for the entire library operation. Since this library system deals with such large volumes of books, most important management decisions and problems revolve around this very important area. The priority system allows the management of the library the flexibility to reallocate their resources in a timely and realistic manner. As overloads appear in certain areas, the priorities can be shifted to reduce the backlogs at those areas. The initial values for levels in the model are given in Figure 6.

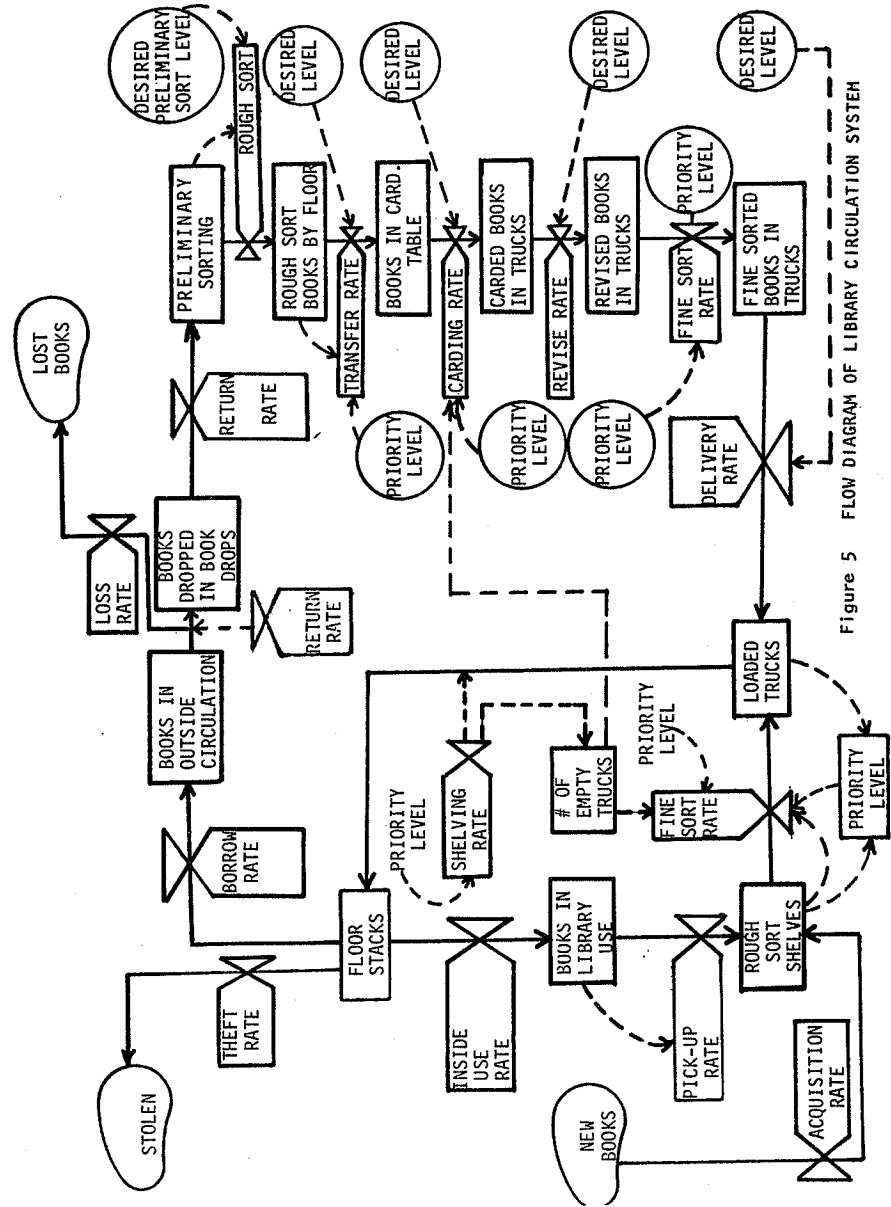

Figure 5 FLOW DIAGRAM OF LIBRARY CIRCULATION SYSTEM

<u>Plaza</u>	<u>Mezzanine</u>	<u>Third Floor</u>	<u>Level Name</u>
140	190	180	Total books dropped in book drop containers
140	190	180	Books in preliminary rough-sort areas inside circulation division book processing areas
210	400	270	Books in rough-sort shelves, by floors
120	120	120	Books in carding tubs or tables
200	300	200	Carded books in trucks
0	0	0	Fine-sorted books in trucks
1600	1600	1600	Fine-sorted books loaded in trucks at the truck parking area, at each floor
8	8	8	Number of loaded trucks in each floor
435	435	435	Number of books in rough-sort area
200,000	230,000	270,000	Number of books in book stacks, available for borrowing or in-library use
100	150	200	Number of books in use within the Library
14,000	20,000	18,000	Number of books in outside circulation
8	8	8	Number of free trucks available for loading

FIGURE 6 - List of Initial Values for Simulation Runs

The approach taken in modelling this library system will be to focus on a "micro" level approach of applying System Dynamics to try to understand the operation of the system from operational decisions that are being made. From this analysis, it will be possible to broaden this analysis to include policy considerations. See (12) for an example of this approach. This problem selected from this library system will be to build a System Dynamics model of the circulation system that realistically replicates current policies and practices with the assumption that the System Dynamics model created will be modified to change some of the resource allocation decisions so that the impact of these changes can be measured and evaluated. There were three main reasons that the circulation system was selected for this analysis:

- (1) This type of system consumes more than fifty percent of the cost of operating most libraries which made it easily the most expensive subsystem.
- (2) A number of tactical decisions made about circulation system policies can have dramatic cost implications to the overall system.
- (3) There was a substantial amount of data readily available concerning this system.

Model Behavior

Figure 7 depicts the output generated by the System Dynamics model. The user of the model must input several critical management parameters to initialize the model. The first two are rates: the fine sort rate and the shelving rate within the system. These rates can vary during the course of a month and depend upon a number of management decisions. The next set of parameters that must be input are the total length of the simulation run which will normally be monthly, length of the priority cycle which indicates how long the priority system established will be held, and the solution interval. The user is then asked to input the dates during the simulation run when priority levels can be shifted within the library system. This allows the model to be responsive to actual work load conditions experienced by the system.

Figure 8 depicts a simulation run with quite similar conditions except that the priority level shifts within the system have been changed. Figure 9 alters the length of the priority cycle substantially and has a number of additional of priority level shifts. From these runs, the management of the library system can test out a number of different management policies and assess their impact on the operation of the library under various criteria.

SUZALO

IN EACH FLOOR: FINE-SORT RATE, SHELVING RATE 72.6
LENGTH OF RUN, LENGTH OF PRIORITY CYCLE, DAYS PER UNIT OF TIME 730*35*1

PRIORITY LEVEL SHIFTS TAKE PLACE ON THE FOLLOWING DATES:

11 23

CIRCULATION: A = PLAZA ROUGH SORT SHELVES B = MEZZANINE ROUGH SORT SHELVES C = 3RD FLC
EACH FLOOR: D = PLAZA ROUGH SORT SHELVES E = MEZZANINE ROUGH SORT SHELVES F = 3RD FLC
EACH FLOOR: G = PLAZA BKS IN PARKED TRKS H = MEZZAN. BKS IN PARKED TRUCKS I = 3RD FL

Table with columns for dates (0, 1010, 2021, 3032, 4043, 5054) and rows for simulation output (0, 10, 20, 30) showing priority shifts (A-I) and floor status (ARDEH, BEH, CREH, BH, EH, H, C, EG, E, CE, G, G, G, G, G, HG, HG, HI, HI, I, I, IG).

Figure 7 Simulation Output

IN EACH FLOOR: FINE-SORT RATE, SHELVES RATE ?2,6
LENGTH OF RUN, LENGTH OF PRIORITY CYCLE, DAYS PER UNIT OF TIME ?30,30,1

PRIORITY LEVEL SHIFTS TAKE PLACE ON THE FOLLOWING DATES:

9 19 29

CIRCULATION: A = PLAZA ROUGH SORT SHELVES B = MEZZANINE ROUGH SORT SHELVES C = 3RD FLOOR
EACH FLOOR: D = PLAZA ROUGH SORT SHELVES E = MEZZANINE ROUGH SORT SHELVES F = 3RD FLOOR
EACH FLOOR: G = PLAZA BKS IN PARKED TRKS H = MEZZAN. BKS IN PARKED TRUCKS I = 3RD FLOOR

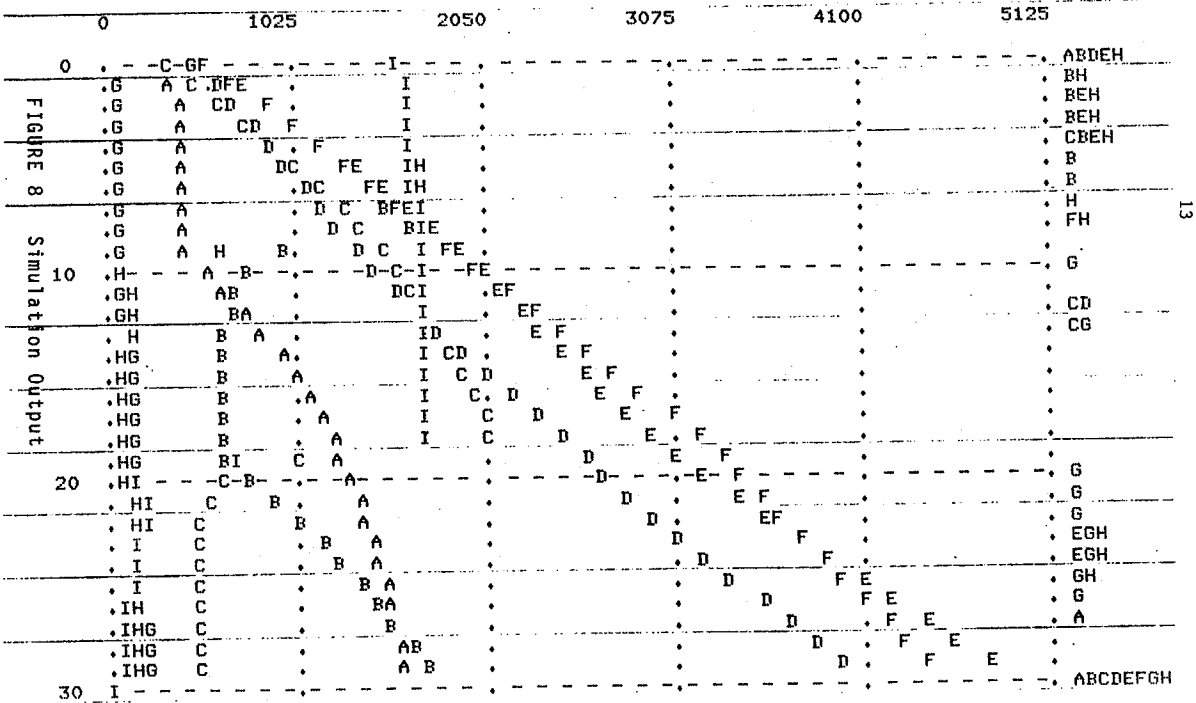

RUN SUZALO

IN EACH FLOOR: FINE-SORT RATE, SHELVES RATE ?4,6
LENGTH OF RUN, LENGTH OF PRIORITY CYCLE, DAYS PER UNIT OF TIME ?30,15,1

PRIORITY LEVEL SHIFTS TAKE PLACE ON THE FOLLOWING DATES:

4 9 14 19 24 29

CIRCULATION: A = PLAZA ROUGH SORT SHELVES B = MEZZANINE ROUGH SORT SHELVES C = 3RD FLOOR
EACH FLOOR: D = PLAZA ROUGH SORT SHELVES E = MEZZANINE ROUGH SORT SHELVES F = 3RD FLOOR
EACH FLOOR: G = PLAZA BKS IN PARKED TRKS H = MEZZAN. BKS IN PARKED TRUCKS I = 3RD FLOOR

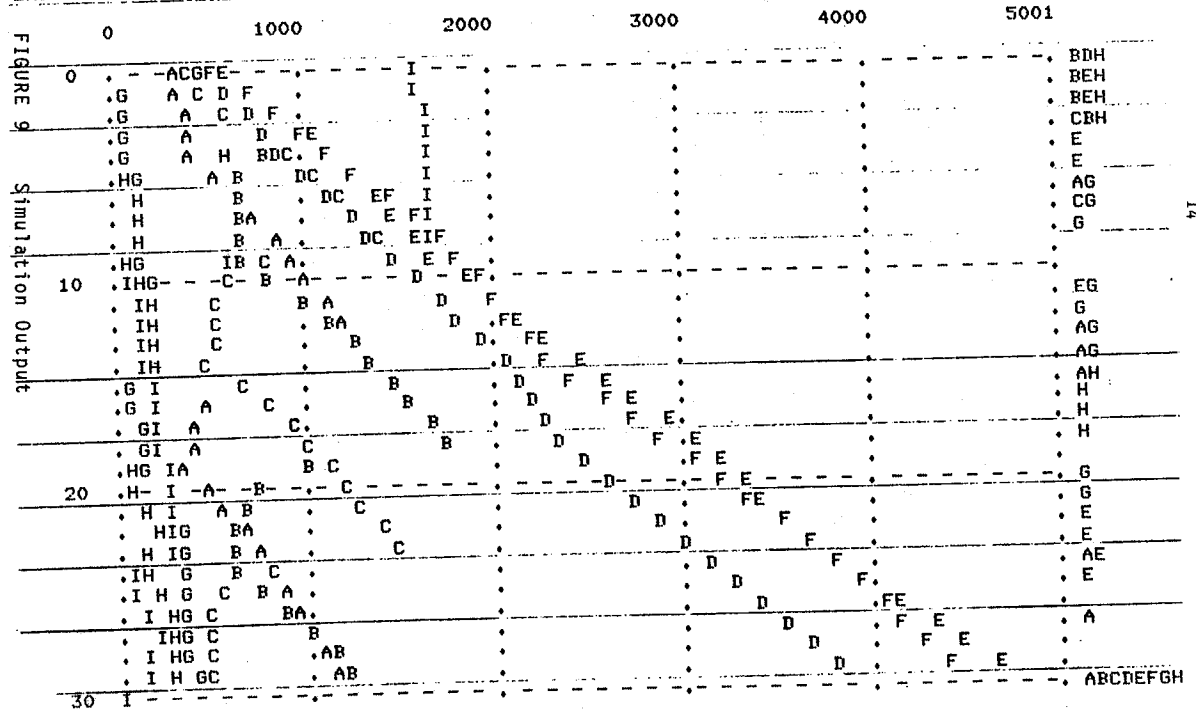

VALIDITY

The issue of model validity is a very perplexing one for a System Dynamics model and this issue has been frequently cited by previous researchers (3)(5)(8) as an important area. This specific issue for the model developed in this paper should be able to answer three basic questions:

1. Does the model explain and predict with reasonable accuracy the actual behavior of the system under study?
2. Are the important elements of the system being modelled correctly?
3. Is the model useful to the decision-maker involved in the management of the system under study?

To the first question, a substantial number of computer simulation runs indicate that the System Dynamics model, within reason accuracy, replicates the current operation of this library circulation system. The measures of this accuracy are book volume counts at various locations within the library system and the physical resources consumed (carts and labor).

To the second question, this model was constructed to allow the key decision makers within the system to modify and adjust the important elements in their decision-making process quickly and easily on this computer model. Such specific things as the sorting rates and shelving rates were established with this in mind. The priority cycle system and when priority levels are to be shifted in time also need to be easily adjustable.

To the last question, since the model developed allows the decision-maker using the model to quickly and easily modify the model to incorporate changes, and view the updated and modified run.

REFERENCES

1. Buckland, M.K. and Hinkle, A. 'Acquisitions, Growth, and Performance Control Through Systems Analysis.' In: Gore, D., editor "Farewell to Alexandria: Solutions to Space, Growth, and Performance Problems in Libraries." Greenwood Publishing Co., 1976.
2. Chen, C.C., "Applications of Operations Research Models to Libraries: A Case Study of the Use of Monographs in the F.A. Countway Library of Medicine, Harvard University." MIT Press, 1976.
3. Coyle, R.G., "Management System Dynamics", Wiley, 1977.
4. Dougherty, R.M. and Heinritz, F.J. "Scientific Management of Library Operations." Scarecrow Press, 1966.
5. Forrester, J. "Industrial Dynamics." MIT Press, 1961.
6. Hamburg, M.; Clelland, R.C.; Bommer, M.R.W.; Ramist, L.E.; and Whitefield, R.M. "Library Planning and Decision-Making Systems." MIT Press, 1974.
7. Lancaster, F.W. "The Measurement and Evaluation of Library Services." Information Services, 1977.
8. Lyneis, J. "Corporate Planning and Policy Design." MIT Press, 1980.
9. Morse, P.M., "Library Effectiveness: A Systems Approach." MIT Press, 1969.
10. _____. "Demand for Library Materials, an Exercise in Probability Analysis." COLLECTION MANAGEMENT Volume 1 (1977), pp. 47-73.
11. _____. "A Queueing Theory, Bayesian Model for the Circulation of Books in a Library." OPERATIONS RESEARCH Volume 27 Number 4 (July-August 1979), pp. 693-716.
12. Wolstenholme, E.F. "Designing and Assessing the Benefits of Control Policies for Conveyor Belt Systems in Underground Coal Mines." DYNAMICA Volume 6 Winter 1980.