

A MULTI-SECTOR MODEL OF INVENTORY-PRODUCTION FLUCTUATIONS: THE IMPACT OF LOCAL INFORMATION ON GLOBAL PERFORMANCE

Ernst W. Diehl
Sloan School of Management
Massachusetts Institute of Technology

ABSTRACT

Inventories of finished goods are added to the static input-output model. This addition allows one to relax the assumption that production can instantaneously track incoming orders. The reformulated input-output model exhibits production-inventory cycles over a wide range of parameter constellations. The model can be used for an extensive dynamic analysis of short-term production-inventory fluctuations in different sectors of the economy. In particular, it can be utilized to understand the extent to which each sector's fluctuations are synchronized and dependent on the fluctuations in the other sectors.

The cause for the potentially oscillatory behavior of the model is analyzed. It is shown that the main reason for the oscillations lies in the assumption that the actors in the model do not know why orders are issued. They cannot distinguish whether incoming orders are issued because the recipients want to adjust their inventories or whether they are issued because the recipients have changed their long-term production plans. This result points out that one dimension of a successful stabilization policy might be an improved information policy. It is suggested that an extension of the model could be used to explain the production-inventory fluctuations during business cycles and to achieve a more detailed understanding of the behavior of different sectors during such cycles.

INTRODUCTION

The analyses of dynamic effects in input-output models has proceeded in two main directions. First, there is the analysis of what have become known as "dynamic input-output models". In this line of research the introduction of capacity, and thus growth is the focus of analysis (Leontief 1953). A thorough discussion of the assumptions of dynamic input-output models is provided in Dorfman (1958). Second, there is the analysis of what can be described as multiplier dynamics. Authors in this line of research showed, how the input-output matrix can be used to compute disaggregated Keynesian multipliers and investigated the conditions that must hold for the input-output matrix to lead to a stable dynamics (Goodwin 1947, Goodwin 1949, Chipman 1950, Metzler 1950, Solow 1952). The research presented in this paper focuses on short-term dynamics and is more closely related to the latter type of models, since it does not deal with aspects of growth.

Most of the input-output multiplier models consider flows only and do not deal with the dynamics caused by the introduction of stocks and stock adjustment policies. It was Metzler (1941, 1947) who first stressed the importance of inventories for understanding production fluctuations. Subsequent studies (Abramovitz 1950, Holt 1960, Mack 1967, Belsley 1969, Hirsch 1969) have added to our understanding of the importance of inventories and of the way companies adjust their inventories.

There have been only a few attempts to combine input-output models with inventory models (Romanoff 1985). In this paper I show how finished-goods inventories and inventory adjustment policies can be added to the input-output multiplier models. The resulting model increases significantly the range of questions that can be analyzed. In addition to the traditional computation of equilibrium behavior it is now possible to address the important question of short-term dynamics. The model exhibits production - inventory cycles over a wide range of parameter constellations. The model can be used to understand the cause of those fluctuations and be used to analyze how the fluctuations in one sector depend on the policies of the affected sector and also on the policies of all other sectors in the economy.

It is the dynamic hypothesis of this paper that the existence of finished-goods inventories and inventory adjustment policies can be central in causing production fluctuations. It is well known that the introduction of delays increases the potential of a system to show oscillations and/or instability. To demonstrate the importance of finished-goods inventories for production-fluctuation, the paper retains the equilibrium-flow character of the original input-output model to a maximum extent and does not introduce any additional delays. In particular, shipments take no time and orders are filled instantaneously. Thus, companies do not need to hold any inventories of intermediate goods.¹

MODEL DESCRIPTION

The model retains all assumptions of a simple, open input-output model. A closed economy with n intermediate sectors and one final demand sector is considered. A linear production function with constant technology is assumed for each sector. There are no constraints on capacity. Prices are fixed. The only change made to the standard input-output model is the relaxation of the assumption that production and incoming orders have to be equal all the time. The provision of a temporary disequilibrium requires an introduction of finished inventories as a buffer between production and sales. It is assumed that the goods produced are manufactured to standard specifications, placed in stock, and shipped out on orders of customers.²

In a model with finished inventories the production decision can be thought of as being separated into two parts. First, production provides an adjustment mechanism to meet incoming orders. Second, production provides an adjustment mechanism to close any gap between desired and actual inventory. Total production (x_i^t) in the i -th sector then can be split into two parts:

$$(1) \quad x_i^t = x_i^o + x_i^h,$$

where x_i^o denotes production due to order adjustments and x_i^h denotes production due to inventory adjustments. The assumptions made about the underlying mechanisms governing these two production adjustment processes have an important influence on model behavior. They are discussed in detail in the following sections.

Determining a best possible rule for the value of x_i^o is one of the central issues in production planning. The task is to find a rational way to react to the day-to-day changes in incoming orders. Changes in orders consist of permanent and transitory components. A production manager will tend to ignore temporary changes, but will have to react to permanent changes. The two components cannot be reliably separated, however. It takes time to gather information and to distinguish between temporary changes in orders and permanent changes. Permanent changes cannot be identified immediately. Rather, a gradual adjustment of beliefs about the permanent values of the order stream will occur. Following this reasoning, the production decision is modeled as an adaptive process.

Using a differential equation and assuming a non-discriminatory adaption process with respect to the origin of orders, the adaption of production to orders for the i -th sector in an n -sector economy can be written as:

$$(2) \quad (d/dt)x_i^o = u_i * [\sum_{j=1..n} (\text{order}_{ij}) + y_i - x_i^o] .$$

In this equation, order_{ij} denotes orders from sector j to sector i and y_i denotes the final demand for the goods of the i -th sector. The policy parameter u_i determines, how fast the sector adjusts production to incoming orders. A high adjustment speed implies that production closely tracks incoming orders. While a high adjustment speed has the advantage that production quickly will adjust to permanent changes in orders, it has the disadvantage that temporary changes in orders affect production to a large extent. As a consequence production will show much of the randomness of the incoming order stream. A low adjustment speed on the other side will lead to a much more stable production pattern. However, production will adjust only slowly to permanent changes in orders. The long-lasting gap between production and orders has to be buffered by the finished-goods inventory, making a large inventory necessary.

Before the second component of total production, production due to inventory adjustments (x_i^h) can be discussed, it is necessary to explain the assumptions made about the reasons for holding an inventory of finished goods. The decision about what amount of inventory to hold is based on a trade-off between the cost of inventory-holding and the costs that are associated with running short of inventory, being unable to deliver and probably loosing costumers. The higher sales are, the more inventory is needed to buffer unexpected temporary changes in orders. In this paper I assume for simplicity that each plant manager tries to maintain a constant inventory / sales coverage. Such a goal might be specified as trying to maintain an average inventory of four weeks worth of sales, for example.

If actual inventory is below desired inventory, production will be increased to make up for the gap. Vice versa, if actual inventory is higher than desired, production will be reduced. Let c_i be the constant coverage factor in sector i . Since expected orders (= expected sales) are equal to x_i^o , desired inventory can be expressed as $(c_i * x_i^o)$.³ Let h_i be the actual inventory of finished goods in sector i . The inventory gap is then computed as $(c_i * x_i^o - h_i)$. It is up to management policy to decide upon how any existing inventory discrepancy should be removed. For mathematical simplicity it is assumed that production due to inventory adjustment (x_i^h) is proportional to the inventory gap:

$$(3) \quad x_i^h = v_i * (c_i * x_i^o - h_i) .$$

Management has to decide upon the speed (v_i), with which an inventory gap should be closed. Again management faces a trade-off. A high value for (v_i) implies that inventory will deviate little from the desired inventory level but that at the same time production has to be very flexible to eliminate quickly any inventory discrepancies. A small value for (v_i) on the other hand allows a stable production pattern but implies that any inventory discrepancy (and the stresses created by this situation) will last for a long time.

Decisions concerning the three policy parameters u_i (the speed with which to adjust the expectations about permanent orders), c_i (the inventory / sales coverage), and v_i (the speed with which to adjust any inventory discrepancies), cannot be made separately but depend on each other. For example, if

the company decides upon a high inventory - sales coverage ratio, it is in a position to allow a slow inventory adjustment speed, since it is not likely to run out of inventory. To determine the optimal values for the three parameters, the underlying cost assumptions and the assumptions about the statistical properties of the incoming order stream have to be made explicit. The values for the parameters are then found as the solution to the resulting optimal control problem.

The remaining equation for orders and actual inventories are easily specified. Orders from sector j to sector i are dependent on total production in sector j (x_j^t) and on the input coefficient a_{ij} . A time-invariant technology is assumed.

$$(4a) \quad \text{order}_{ij} = a_{ij} * x_j^t$$

Making use of (1) and substituting for x_j^h , the term can be written as:

$$(4b) \quad \text{order}_{ij} = a_{ij} * [x_j^o + x_j^h] = a_{ij} * [x_j^o + v_j * (c_j * x_j^o - h_j)]$$

The inventory of finished goods is defined as the accumulation of production minus shipments. Since incoming orders are filled instantaneously,⁴ shipments equal orders and the change in finished inventory can be written as:

$$(5) \quad \begin{aligned} (d/dt)h_i &= x_i^t - \sum_{j=1..n}(\text{order}_{ij}) - y_i \\ &= x_i^o + v_i * (c_i * x_i^o - h_i) - \sum_{j=1..n}(\text{order}_{ij}) - y_i \end{aligned}$$

Substituting (4b) into (2) and into (5) yields the following two equations that completely describe the behavior of the i -th sector over time:

$$(6) \quad \begin{aligned} (d/dt)x_i^o &= -u_i * x_i^o + u_i * \sum_{j=1..n} (a_{ij} * x_j^o + a_{ij} * v_j * c_j * x_j^o) - u_i * \sum_{j=1..n} (a_{ij} * v_j * h_j) + u_i * y_i \\ (d/dt)h_i &= (1 + v_i * c_i) * x_i^o - v_i * h_i - \sum_{j=1..n} (a_{ij} * x_j^o + a_{ij} * v_j * c_j * x_j^o) + \sum_{j=1..n} (a_{ij} * v_j * h_j) - y_i \end{aligned}$$

Figure 1 on the next page shows the stock-flow diagram for the model.

Figure 1: Stock-flow diagram

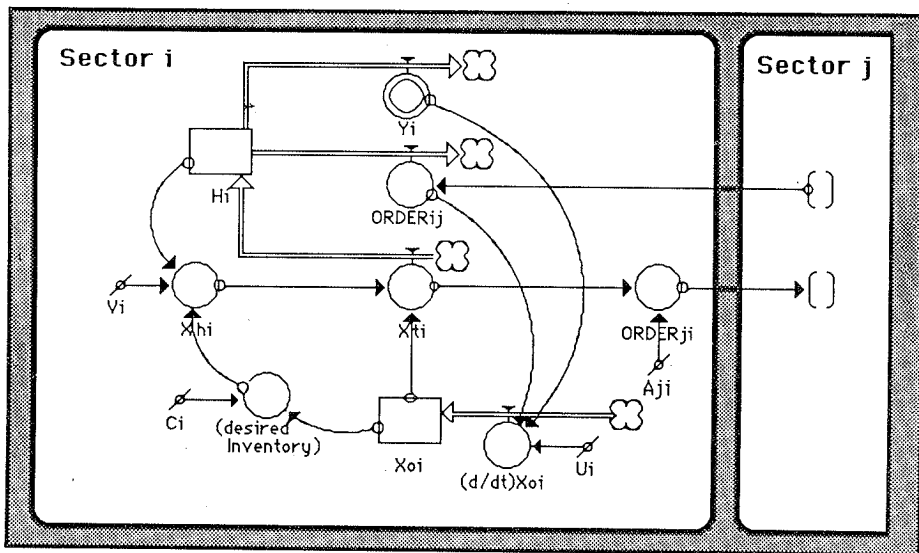

MODEL ANALYSIS

Define the following diagonal matrices for inventory coverage (C), speed of production adjustment to orders (U) and speed of inventory-gap adjustment (V) for an n-sector economy:

$$C = \begin{vmatrix} c_1 & & & \\ & \cdot & & \\ & & c_i & \\ & & & \cdot \\ & 0 & & \\ & & & c_n \end{vmatrix} \quad
 U = \begin{vmatrix} u_1 & & & \\ & \cdot & & \\ & & u_i & \\ & & & \cdot \\ & 0 & & \\ & & & u_n \end{vmatrix} \quad
 V = \begin{vmatrix} v_1 & & & \\ & \cdot & & \\ & & v_i & \\ & & & \cdot \\ & 0 & & \\ & & & v_n \end{vmatrix}$$

Further, let A be the input coefficient matrix, X^0 the vector of planned production due to incoming orders, H the vector of finished inventory in each sector and Y the vector of final demand:

$$A = \begin{vmatrix} a_{11} & \cdot & a_{1n} \\ \cdot & & \cdot \\ \cdot & a_{ij} & \cdot \\ \cdot & \cdot & \cdot \\ a_{n1} & \cdot & a_{nn} \end{vmatrix} \quad
 X^0 = \begin{vmatrix} x^0_1 \\ \cdot \\ x^0_i \\ \cdot \\ x^0_n \end{vmatrix} \quad
 H = \begin{vmatrix} h_1 \\ \cdot \\ h_i \\ \cdot \\ h_n \end{vmatrix} \quad
 Y = \begin{vmatrix} y_1 \\ \cdot \\ y_i \\ \cdot \\ y_n \end{vmatrix}$$

The equation system (6) then can be written as:

$$(7) \begin{vmatrix} (d/dt)X^o \\ \hline (d/dt)H \end{vmatrix} = \begin{vmatrix} -U * (I - A - A * V * C) & : & -U * A * V \\ \hline (I - A) * (I + V * C) & : & -(I - A) * V \end{vmatrix} \begin{vmatrix} X^o \\ \hline H \end{vmatrix} + \begin{vmatrix} U \\ \hline -I \end{vmatrix} * Y$$

Using Laplace transforms, the time-response of the system with respect to orders from final demand can be expressed as:

$$(8a) \begin{vmatrix} X^o(s) \\ \hline H(s) \end{vmatrix} = \begin{vmatrix} s * I + U * (I - A - A * V * C) & : & U * A * V \\ \hline -(I - A) * (I + V * C) & : & s * I + (I - A) * V \end{vmatrix} \begin{vmatrix} U \\ \hline -I \end{vmatrix} * Y(s)$$

or as:

$$(8b) \begin{vmatrix} X^o(s) \\ \hline H(s) \end{vmatrix} = \begin{vmatrix} [\Omega_a - \Omega_b \Omega_d^{(-1)} \Omega_c]^{(-1)} & : & -\Omega_a^{(-1)} \Omega_b [\Omega_d - \Omega_c \Omega_a^{(-1)} \Omega_b]^{(-1)} \\ \hline -\Omega_d^{(-1)} \Omega_c [\Omega_a - \Omega_b \Omega_d^{(-1)} \Omega_c]^{(-1)} & : & [\Omega_d - \Omega_c \Omega_a^{(-1)} \Omega_b]^{(-1)} \end{vmatrix} \begin{vmatrix} U \\ \hline -I \end{vmatrix} * Y(s)$$

where

$$\begin{aligned} \Omega_a &= s * I + U * (I - A - A * V * C) \\ \Omega_b &= -U * A * V \\ \Omega_c &= (I - A) * (I + V * C) \\ \Omega_d &= s * I + (I - A) * V \end{aligned}$$

As shown in Appendix Ia, the resulting equilibrium (for all parameter constellations that lead to a stable adjustment path) is computed as:

$$(9) \begin{vmatrix} X^o (s \rightarrow 0) \\ \hline H (s \rightarrow 0) \end{vmatrix} = \begin{vmatrix} (I - A)^{(-1)} \\ \hline C * (I - A)^{(-1)} \end{vmatrix} * Y$$

The result is as expected. The equilibrium value for production confirms the solution for the static input-output model, and inventory equals desired inventory in equilibrium. More interesting than the computation of equilibrium values, is an examination of the disequilibrium properties of the system. While a comprehensive analysis of the transient and frequency response of the model is beyond the scope of this paper, an eigenvalue analysis of the system provides a good first insight into the dynamic response of the model. The 2*n eigenvalues of the model are computed by solving equation (10) with respect to s:

$$(10) \text{DET} \{ [s * I + U * (I - A - A * C * V)] * [s * I + (I - A) * V] + (I - A) * (I + V * C) * U * A * V \} = 0$$

Without solving explicitly, it can be seen that the behavior modes of production and finished inventory in one sector, depend on the input coefficients and the policy parameters in all other sectors. The system exhibits oscillations over a wide range of parameter constellations and can be unstable. An example might be useful to illustrate the behavior of the system. I set n=2 and assumed for convenience identical production and inventory planning policies in each of the two sectors. I chose as parameter values: inventory coverage = 2 months of production, average adjustment time of inventory = 3 months and average time to adjust to orders = 2 months (c₁=c₂=2, v₁=v₂=0.33, u₁=u₁=0.5). I assumed a symmetric input-coefficient matrix with a₁₁ = a₁₂ = a₂₁ =

Figure 2a: Inventory and production in sector 1:

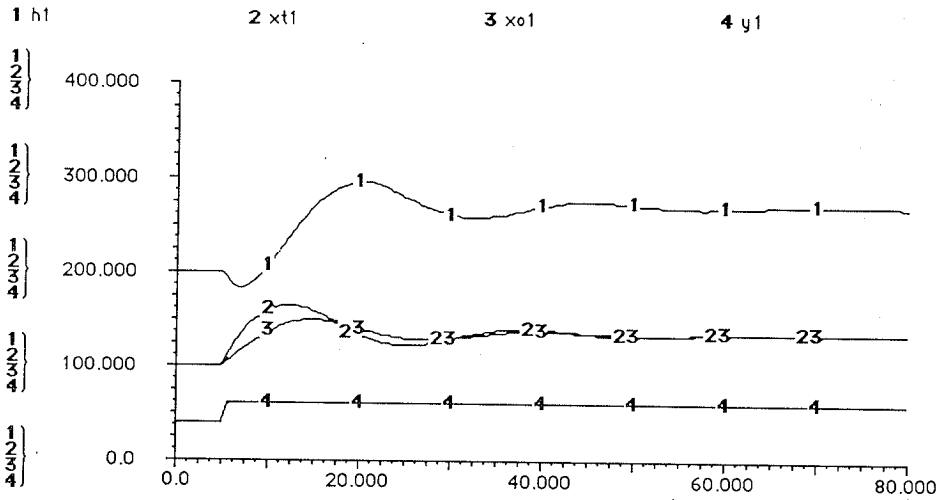
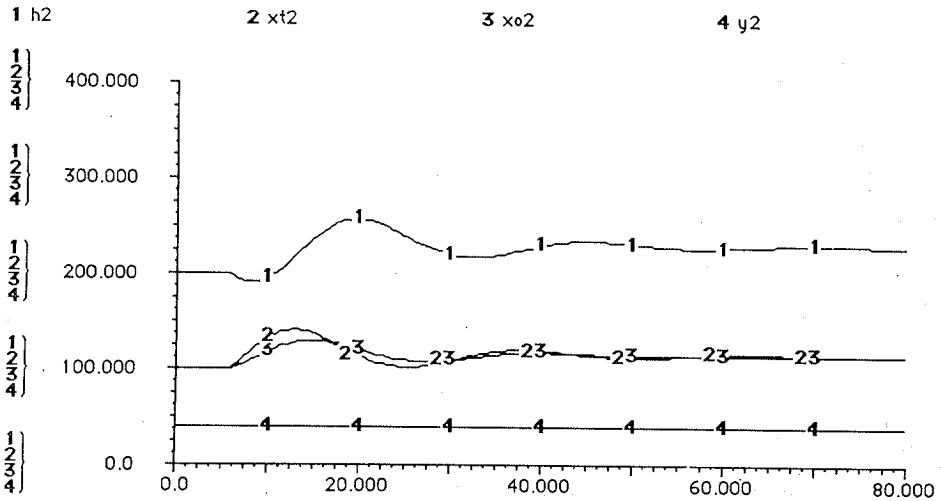

Figure 2b: Inventory and production in sector 2:



$a_{22} = 0.3$. A system initially in equilibrium with $h_1 = h_2 = 40$, $x^h_1 = x^h_2 = 0$, $x^t_1 = x^o_1 = x^t_2 = x^o_2 = 100$ and $y_1 = y_2 = 40$ exhibits the behavior shown in Figures 2a and 2b in response to a sudden 20 unit increase in exogenous orders for sector 1 at time=5.

Why does the system tend to oscillate? The underlying cause is an information problem. Production managers cannot tell whether an incoming order reflects changes in long - term demand patterns or whether an incoming order is issued "merely" because of inventory adjustments in other companies. Both types of orders occur simultaneously in response to a change in final-demand.

First, as sector 1 gradually adjusts its belief about higher permanent orders in response to the increase in exogenous orders, production increases. Higher production in sector 1 implies higher orders for intermediate inputs to sector 2 and sector 1. By means of the well-known multiplier chain, both sectors adjust gradually their production in response to the higher final demand for sector 1 and to the increased need for intermediate inputs it implies. This change in production reflects a necessary adjustment to a long-lasting change in orders.

Second, both sectors face an initial decline in inventories, since production lags behind the increase in sales. Production has to temporarily increase to close the gap between actual inventories and desired inventories. Again, the higher production implies higher orders for intermediate inputs. As both sectors adjust their production and desired inventory levels to the increased need for intermediate inputs, they do not take into account that all orders issued to accommodate an inventory adjustment can only be temporary. Once the inventory adjustment is complete, production due to inventory adjustment declines back to zero. This decline in production implies a decline in the need for intermediate inputs. Once it becomes apparent that the production level in both sectors is higher than justified by long-term demand, the economy faces a downturn and inventory and production eventually undershoot their long-term equilibrium values. As a response a new upturn begins etc. until the economy gradually swings into a new equilibrium.

The assumption of incomplete information seems to reflect the real-world situation. In a hypothetical model world, however, it is possible to change this assumptions in order to test the hypothesis that it is indeed incomplete information that is at the base of the fluctuations.

Assume that each order has a label attached to it, describing it either as an order issued to adjust inventories or as an order issued to meet long-lasting demand. Thus, total orders can be expressed as sum of long-lasting orders and of temporary orders (due to inventory adjustments) or:

$$\begin{aligned} \text{order}^t_{ij} &= \text{order}^o_{ij} + \text{order}^h_{ij}, \text{ where} \\ \text{order}^o_{ij} &= a_{ij} * x^o_j \\ \text{order}^h_{ij} &= a_{ij} * x^h_j = a_{ij} * v_j * (c_j * x^o_j - h_j). \end{aligned}$$

Provided with the additional information, it is possible to make the expectations about permanent orders a function of long-lasting orders only. Disturbances created by short-run orders are no longer transmitted into the planning decisions, but are buffered by finished inventory. The changes of production in response to orders can now be formulated as:

$$(2^*) \quad (d/dt)x^o_i = u_i * [\sum_{j=1..n} (\text{order}^o_{ij}) + y_i - x^o_i].$$

The equation for production due to inventory adjustments and the equation for inventory behavior remain unchanged. Thus:

$$(5^*) \quad (d/dt)h_i = x^o_i + v_i * (c_i * x^o_i - h_i) - \sum_{j=1..n} (\text{order}^t_{ij}) - y_i.$$

Substituting for order^o_{ij} and order^t_{ij}, respectively, yields the revised system description:

$$(6^*) \begin{aligned} (d/dt)x_i^o &= -u_i * x_i^o + u_i * \sum_{j=1..n} (a_{ij} * x_j^o) + u_i * y_i \\ (d/dt)h_i &= (1 + v_i * c_i) * x_i^o - v_i * h_i - \sum_{j=1..n} (a_{ij} * x_j^o + a_{ij} * v_j * c_j * x_j^o) + \sum_{j=1..n} (a_{ij} * v_j * h_j) - y_i \end{aligned}$$

Comparing (6*) with (6) shows that the expectation about long-lasting orders (x^o_i) is no longer influenced by the existence of temporary orders due to inventory-adjustments. In particular, (x^o_i) is no longer dependent on the state of actual inventories in the n-sectors (h₁, ..., h_n). The system is now partially decoupled.

The new equation system can be written as:

$$(7^*) \begin{vmatrix} (d/dt)X^o \\ (d/dt)H \end{vmatrix} = \begin{vmatrix} -U * (I - A) & : & 0 \\ (I - A) * (I + V * C) & : & -(I - A) * V \end{vmatrix} \begin{vmatrix} X^o \\ H \end{vmatrix} + \begin{vmatrix} U \\ -I \end{vmatrix} * Y$$

Using Laplace transforms again, the time-response of the new system with respect to orders from final demand is expressed as:

$$(8a^*) \begin{vmatrix} X^o(s) \\ H(s) \end{vmatrix} = \begin{vmatrix} s * I + U * (I - A) & : & 0 \\ - (I - A) * (I + V * C) & : & s * I + (I - A) * V \end{vmatrix}^{(-1)} \begin{vmatrix} U \\ -I \end{vmatrix} * Y(s)$$

or as:

$$(8b^*) \begin{vmatrix} X^o(s) \\ H(s) \end{vmatrix} = \begin{vmatrix} \Omega_a^{(-1)} & : & 0 \\ -\Omega_d^{(-1)} \Omega_c \Omega_a^{(-1)} & : & \Omega_d^{(-1)} \end{vmatrix} \begin{vmatrix} U \\ -I \end{vmatrix} * Y(s)$$

where

$$\begin{aligned} \Omega_a &= s * I + U * (I - A) \\ \Omega_c &= (I - A) * (I + V * C) \\ \Omega_d &= s * I + (I - A) * V \end{aligned}$$

Applying the Final Value Theorem again, yields that the equilibrium values are unchanged (see Appendix 1b):

$$(9^*) \begin{vmatrix} X^o(s \rightarrow 0) \\ H(s \rightarrow 0) \end{vmatrix} = \begin{vmatrix} (I - A)^{(-1)} \\ C * (I - A)^{(-1)} \end{vmatrix} * Y$$

The 2*n eigenvalues of the model are computed by solving equation (9*) with respect to s:

$$(10^*) \text{DET}\{[s * I + U * (I - A)] * [s * I + (I - A) * V]\} = \text{DET}\{[s * I + U * (I - A)]\} * \text{DET}\{[s * I + (I - A) * V]\} = 0$$

Now the system is partially decoupled. The parameters that govern the inventory policies no longer influence the production response. Inventory coverage does not influence the modes at all. The

Figure 3a: Inventory and production in sector 1 (information added):

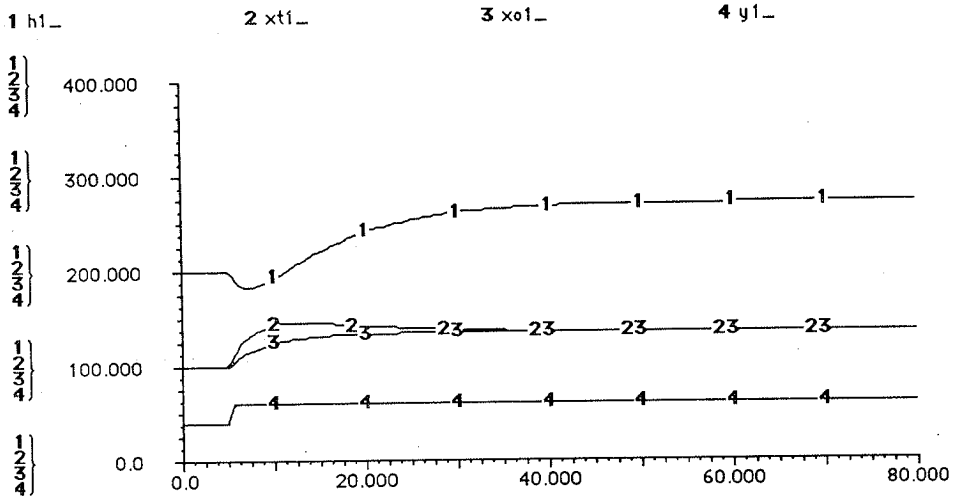
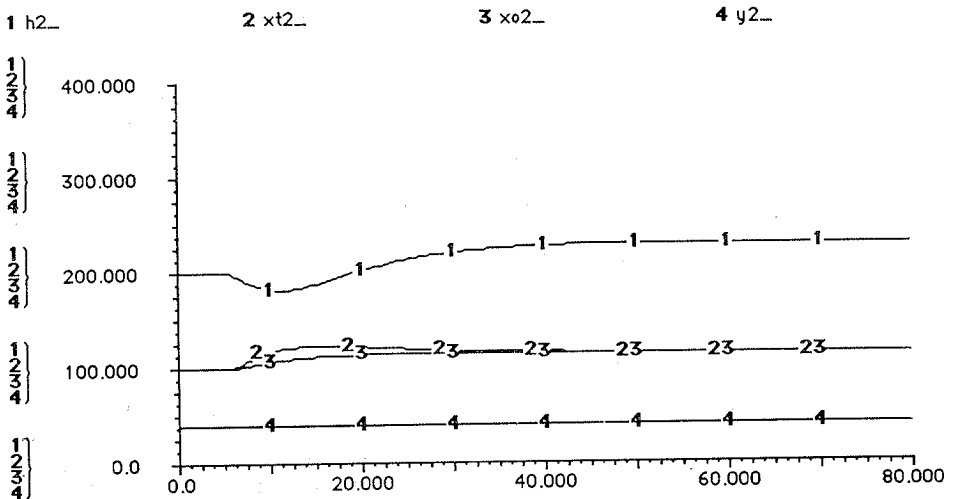

Figure 3b: Inventory and production in sector 2 (information added):



system is now distinctively more stable. To illustrate the behavior of the system, the behavior for the revised system is shown in Figures 3a and 3b. The same parameter values as above are assumed.

The system no longer oscillates in this example. Total production overshoots its long-run equilibrium once. This one-time overshoot is necessary to make up for the initial fall in inventories and to adjust inventories to the new desired value. However, the overshoot in production and the implied temporary increase in orders for intermediate goods does not change the long-run production and inventory plans. Thus, the economy adjusts to the new equilibrium without oscillations.⁵

CONCLUSIONS

The model of inventory-production fluctuations developed in this paper showed how intended rational decisions about production and inventory management in a decentralized system can lead to an overall economic performance that is less than optimal. The model analysis revealed that insufficient information is the cause for the sub-optimal behavior of the overall system. By associating costs to inventory discrepancies and to production fluctuations and by comparing the economic performance in a system with and without information, it would be possible to explicitly assess the value of the missing information.

The type of information provided to the decision-makers in this paper can be contrasted with the information embedded in expectations. More accurate expectations of the future could also, presumably, improve performance. An interesting extension to this paper would be a detailed consideration of the costs and benefits of improved expectation formations versus the costs and benefits of the type of information discussed in this paper.

No attempts have been made in this paper to empirically test the model and to compare the fluctuations produced by the model to empirically observable business-cycle fluctuations. The model is based on a minimum set of variables and assumptions. It does not contain interest rates, prices or wages nor does it contain a labor or capital market. Since the business cycle is a phenomenon that involves more variables than just production and inventories of finished goods, the model might be considered a bare-bones business-cycle model. However, it seems that an extension of the model could be very useful in moving towards a behaviorally based, sectorally disaggregated theory of business cycles.

Sectorally disaggregated models provide an understanding of business cycle that is far more detailed than insights gained by aggregated models alone. Disaggregated models allow one to come to sector-specific results. For example, one outcome of the model discussed in this paper is to expect that sectors with different inventory policies will be influenced quite differently during the business cycle. It is then possible to derive sector-specific policy recommendations rather than undifferentiated global advice.

The main advantage of behaviorally based models is that it is easily possible to assess what bounds on information availability are central in causing an overall behavior that is less than optimal. Based on this knowledge, it is possible to define policies that are directed at the causes of the underperformance rather than at its symptoms. Such a business cycle model might help to deemphasize attempts to counteract cycles by means of fiscal and monetary measures and shift attention towards creating a business cycle information system.

NOTES:

- ¹ The strong focus on inventories for finished goods does not imply that inventories of intermediate goods and delays in shipment and production processing are unimportant for the dynamics of the system. See an earlier paper (Diehl 1985) for an integrated treatment of these factors.
- ² While I deal in this paper exclusively with production to stocks, it is not conceptually difficult to allow for production to orders. One consistent way of modeling such a situation is to endow each sector with n backlogs, allowing the sector to keep track of not yet filled orders. In such a model, shipments can no longer be instantaneously equal to orders. Now, they are dependent on the rate with which the delivering sector reduces its backlog. Analogous to the inventory adjustment policy, the backlog adjustment policy could be modeled as an adjustment process towards a desired normal backlog that each sector wishes to maintain. Note that such a model extension would imply considerable mathematical complications, since $n \times n$ states would be added to the model.
- ³ It is important to specify desired inventory as a function of (x^0_i) and not as a function of (x^1_i) . Since production due to inventory adjustment (x^h_i) is one component of (x^1_i) , a specification of desired inventory as a function of total production would introduce artificial fluctuations into the system: As desired inventory goes up, production due to inventory adjustment (and thus total production) increases, leading artificially to an even higher value for desired inventory. One consequence of the distinction is to use sales figures instead of production figures in an econometric investigation of production-inventory behavior.
- ⁴ Since shipments are not constrained by available inventory, the model does not prevent inventory from becoming negative in the case of unanticipated high orders. One might want to think of this model as a linearized version of a more realistic non-linear model about a "normal" point of operation.
- ⁵ Although the economy is distinctively more stable in the case with information, oscillations cannot be completely ruled out for specific parameter constellations, as can be seen through an analysis of the eigenvalues of the system. However, those specific oscillations have a different cause. As an intuitive example, consider an economy where sector 1 delivers only to sector 2, sector 2 delivers only to sector 3, etc. until finally sector n delivers only to sector 1 and thus closes a chain. Imagine a increase in final demand for sector 1. The induced increase in orders for intermediate inputs "travels" slowly through the sectors of the economy until it reaches sector n . At the time when sector n finally reacts and increases its orders to sector 1, sector 1 has already completed its initial production adjustment to the change in final demand. Now sector 1 faces a new increase in orders and sets off a new wave of adjustments.

REFERENCES

- Abramovitz, Moses. (1950) Inventories and business cycles, with special reference to manufacturers' inventories. Studies in business cycles No. 4. National Bureau of Economic Research. New York.
- Belsley, David A. (1969) Inventory production behavior. The order-stock distinction. North - Holland Publishing Company. Amsterdam.
- Chipman, John S. (1950) The multi-sector multiplier. In: *Econometrica*. Pp. 355-374.
- Diehl, Ernst W. (1985) Adjustment dynamics in a static input-output model. In: *Proceedings of the 1985 International Conference of the System Dynamics Society*, July 2-5. Keystone, Colorado. Pp.161-178.
- Dorfman, Robert, Samuelson, Paul A. and Solow, Robert M. (1958) Linear programming and

economic analysis. McGraw-Hill. New York, Toronto, London.

Goodwin, Richard M. (1949) The multiplier as matrix. In: *The Economic Journal*. Pp. 537-555.

Goodwin, Richard M. (1947) Dynamical coupling with especial reference to markets having production lags. In: *Econometrica*. Pp. 181-204.

Hirsch, Albert A. and Lovell, Michael C. (1969) *Sales anticipations and inventory behavior*. Wiley. New York.

Holt, Charles C., Modigliani, Franco, Muth, John F. and Simon, Herbert A. (1960) *Planning production, inventories, and workforce*. Prentice Hall. Englewood Cliffs, N.J.

Leontief, Wassily. (1953) *Dynamic analysis*. In: *Studies in the structure of the American economy*. Oxford University Press. Pp. 53-90. New York.

Mack, Ruth P. (1967) *Information, expectations, and inventory fluctuation*. National Bureau of Economic Research. Columbia University Press. New York, London.

Metzler, Lloyd A. (1941) The nature and stability of inventory cycles. In: *Review of Economics and Statistics*. Pp. 113-129.

Metzler, Lloyd A. (1947) Factors governing the length of inventory cycles. In: *Review of Economics and Statistics*. Pp. 1-15.

Metzler, Lloyd A. (1950) A multiple-region theory of income and trade. In: *Econometrica*. Pp. 329-354.

Romanoff, Eliahu and Levine, Stephen H. (1985) Capacity limitations, inventory and time-phased production in the sequential interindustry model. Paper presented at the Thirty-Second North American Meetings of the Regional Science Association, November 15-17. Philadelphia, PA.

Solow, Robert. (1952) On the structure of linear models. In: *Econometrica*. Pp. 29-46.

APPENDIX Ia: FINAL VALUE COMPUTATION FOR BASE MODEL

Taking equation (8b) and applying the Final Value Theorem, the equilibrium values (for all parameter constellations that lead to a stable adjustment path) are computed by solving:

$$\begin{array}{l|l} | X^0(s>0) | & | [\Omega_a - \Omega_b \Omega_d^{(-1)} \Omega_c]^{(-1)} * U * Y + \Omega_a^{(-1)} \Omega_b [\Omega_d - \Omega_c \Omega_a^{(-1)} \Omega_b]^{(-1)} * Y | \\ | \dots | & | \dots | \\ | H(s>0) | & | -\Omega_d^{(-1)} \Omega_c [\Omega_a - \Omega_b \Omega_d^{(-1)} \Omega_c]^{(-1)} * U * Y - [\Omega_d - \Omega_c \Omega_a^{(-1)} \Omega_b]^{(-1)} * Y | \end{array}$$

where

$$\begin{aligned} \Omega_a &= U * (I - A - A * V * C) \\ \Omega_b &= - U * A * V \\ \Omega_c &= (I - A) * (I + V * C) \\ \Omega_d &= (I - A) * V \end{aligned}$$

Substituting:

$$\begin{aligned} X^0(s>0) &= \{ [U * (I - A - A * V * C)] - [U * A * V] [(I - A) * V]^{(-1)} [- (I - A) * (I + V * C)] \}^{(-1)} * U * Y \\ &\quad + \Omega_a^{(-1)} \Omega_b * \{ [(I - A) * V] + [(I - A) * (I + V * C)] * \Omega_a^{(-1)} \Omega_b \}^{(-1)} * Y \\ &= \{ U * (I - A - A * V * C) - (U * A) * (I + V * C) \}^{(-1)} * U * Y \\ &\quad + \Omega_a^{(-1)} \Omega_b * \{ [(I - A) * V * \Omega_b^{(-1)} \Omega_a + (I - A) * (I + V * C)] * \Omega_a^{(-1)} \Omega_b \}^{(-1)} * Y \\ &= Y + [V * \Omega_b^{(-1)} \Omega_a + (I + V * C)]^{(-1)} * (I - A)^{(-1)} * Y \end{aligned}$$

$$\begin{aligned}
 &= Y + [V*V^{(-1)}*A^{(-1)}*U^{(-1)}*U*(I - A - A*V*C) + (I+V*C)]^{(-1)}*(I-A)^{(-1)}*Y \\
 &= (I-A)*(I-A)^{(-1)}*Y + [A^{(-1)} - I - V*C + I+V*C]^{(-1)}*(I-A)^{(-1)}*Y \\
 &= (I - A + A)*(I-A)^{(-1)}*Y = (I-A)^{(-1)}*Y
 \end{aligned}$$

$$\begin{aligned}
 H(s->0) &= [(I-A)*V]^{(-1)}(I-A)*(I+V*C) \\
 &\quad * \{ U*(I-A-A*V*C) - [U*A*V][(I-A)*V]^{(-1)}[-(I-A)*(I+V*C)] \}^{(-1)}*U*Y \\
 &\quad - \{ [(I-A)*V] - [(I-A)*(I+V*C)] \Omega_a^{(-1)}\Omega_b \}^{(-1)}*Y \\
 &= V^{(-1)}*(I+V*C) * \{ U - U*A - U*A*V*C + U*A*(I+V*C) \}^{(-1)}*U*Y \\
 &\quad - \{ [(I-A)*V*\Omega_b^{(-1)}\Omega_a + (I-A)*(I+V*C)] \Omega_a^{(-1)}\Omega_b \}^{(-1)}*Y \\
 &= V^{(-1)}*(I+V*C) * Y \\
 &\quad - \{ [(I-A)*A^{(-1)}*(I-A-A*V*C) + (I-A)*(I+V*C)] \Omega_a^{(-1)}\Omega_b \}^{(-1)}*Y \\
 &= V^{(-1)}*(I+V*C) * Y - \{ [(I - A)*A^{(-1)}] *(I-A-A*V*C)^{(-1)}*A*V \}^{(-1)}*Y \\
 &= V^{(-1)}*(I+V*C) * Y - V^{(-1)}*A^{(-1)}*(I-A-A*V*C)*A*(I-A)^{(-1)} * Y \\
 &= [V^{(-1)}*(I+V*C) * (I-A) - V^{(-1)}*A^{(-1)}*(I-A-A*V*C)*A] * (I-A)^{(-1)} * Y \\
 &= [V^{(-1)} + C - V^{(-1)}*A - C*A - V^{(-1)} + V^{(-1)}*A + C*A]*(I-A)^{(-1)} * Y \\
 &= C * (I-A)^{(-1)} * Y
 \end{aligned}$$

Thus, we obtain the result:

$$\left| \begin{array}{c} X^o (s->0) \\ \hline H (s->0) \end{array} \right| = \left| \begin{array}{c} (I - A)^{(-1)} \\ \hline C * (I - A)^{(-1)} \end{array} \right| * Y$$

APPENDIX Ib: FINAL VALUE COMPUTATION FOR MODEL WITH ADDITIONAL INFORMATION

Taking equation (8b*) and applying the Final Value Theorem, the equilibrium values (for all parameter constellations that lead to a stable adjustment path) are computed by solving:

$$\begin{vmatrix} X^0(s \rightarrow 0) \\ \hline H(s \rightarrow 0) \end{vmatrix} = \begin{vmatrix} \Omega_a^{(-1)} * U * Y \\ \hline -\Omega_d^{(-1)} \Omega_c \Omega_a^{(-1)} * U * Y - \Omega_d^{(-1)} * I * Y \end{vmatrix}$$

where

$$\Omega_a = U * (I - A)$$

$$\Omega_c = -(I - A) * (I + V * C)$$

$$\Omega_d = (I - A) * V.$$

Substituting:

$$\begin{aligned} X^0(s \rightarrow 0) &= [U * (I - A)]^{(-1)} * U * Y \\ &= (I - A)^{(-1)} * U^{(-1)} * U * Y \\ &= (I - A)^{(-1)} * Y \end{aligned}$$

$$\begin{aligned} H(s \rightarrow 0) &= -[(I - A) * V]^{(-1)} * [-(I - A) * (I + V * C)] * [U * (I - A)]^{(-1)} * U * Y - [(I - A) * V]^{(-1)} * Y \\ &= V^{(-1)} * (I - A)^{(-1)} * (I - A) * (I + V * C) * (I - A)^{(-1)} * U^{(-1)} * U * Y - V^{(-1)} * (I - A)^{(-1)} * Y \\ &= V^{(-1)} * (I + V * C) * (I - A)^{(-1)} * Y - V^{(-1)} * (I - A)^{(-1)} * Y \\ &= [V^{(-1)} + V^{(-1)} * V * C - V^{(-1)}] * (I - A)^{(-1)} * Y \\ &= C * (I - A)^{(-1)} * Y \end{aligned}$$

Thus:

$$\begin{vmatrix} X^0(s \rightarrow 0) \\ \hline H(s \rightarrow 0) \end{vmatrix} = \begin{vmatrix} (I - A)^{(-1)} \\ \hline C * (I - A)^{(-1)} \end{vmatrix} * Y$$