

A PROTOTYPE EXPERT SYSTEM FOR SYSTEM DYNAMICS MODELLING

Mitsuo KISHI, Keitaro NODA, Yuji YAMASHITA, and Katashi TAGUCHI

Department of Naval Architecture, College of Engineering,  
University of Osaka Prefecture, Sakai, Osaka 591, JAPAN

ABSTRACT

In this study, a prototype expert system to support system dynamics modelling is designed by organizing the knowledge structures of generic patternized expectations and the rules on how to construct system dynamics models. The system is a production-rule-oriented consultation system written in PROLOG. The proposed system covers the system conceptualization in part, system modelling, and generation of simulation program. Brief executing processes of the proposed system are: 1) Extracting concepts(nodes) within a system by perceiving action/decision making and by inferring the causal relations(links). 2) Preparing a causal-loop diagram of the system automatically by interconnecting the causal relations and by eliminating inappropriate links. 3) Transforming the causal-loop diagram into a flow-diagram automatically, and generating a simulation program. The proposed system has a knowledge base of facts acquired in the systems modelling, to facilitate the modelling of a system related to the ones dealt with in the past. Some application examples are provided to verify the applicability of the proposed system.

1. INTRODUCTION

When analyzing a multi-correlated problem related to technological, social and/or ecological items, it may be appropriate to employ not a conventional extrapolation model, but a structural model, e.g. system dynamics model (Forrester 1961). In system dynamics, it is possible to simulate system behaviour quantitatively using DYNAMO (Pugh 1976) after the system modelling (system identification). However, system modelling is presented by specialists basing on their own knowledge and experience about both the system and system dynamics, that is to say not a systematic way. Therefore, some heuristic computer aided techniques for structural modelling, such as ISM, Cognitive Map (Axelrod 1976, Kishi 1986), etc., have been proposed, but they are not so precise for system dynamics modelling.

In this study, a prototype expert system to support system dynamics modelling is designed by organizing the knowledge structures of generic patternized expectations and the rules on how to construct system dynamics models. The system is a production-rule-oriented consultation system encoded in PROLOG (Clocksin 1983). PROLOG, which is a programming language based on predicate logic (Chang, 1973), is becoming popular for Artificial Intelligence research. And it is good for processing causal relations in system dynamics models (Nilsson 1980, Nolan 1986, Elzas 1986).

The process of system dynamics inquiry consists of two phases as shown in

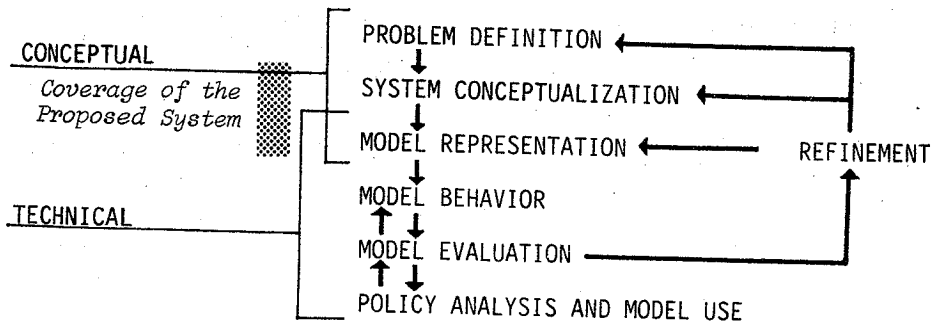

Figure 1 Process of system dynamics inquiry (Andersen 1980, Roberts 1983)

Figure 1 (Andersen 1980, Roberts 1983): i) Conceptual phase, which addresses the problem definition and system conceptualization. ii) Technical phase, which addresses the system modelling, simulation of system behaviour, evaluation of model validity, and system analysis. The conceptual phase is critically important; however, it is close to being an art. For the above process, the proposed system in this study covers the system conceptualization in part and the model representation.

Brief executing processes of the proposed system are: 1) Extracting concepts(nodes) within a system by perceiving action/decision making and by inferring the causal relations(links). 2) Preparing a causal-loop diagram of the system automatically by integrating the causal relations and by eliminating inappropriate links so as to be precise for system dynamics models. 3) Transforming the causal-loop diagram into a flow-diagram by identifying system levels, rates, auxiliaries and parameters automatically. 4) Generating a simulation program (in BASIC) semiautomatically by defining equations on the causal relations and specifying initial values for variables, etc.

To facilitate future modelling work about a system related to the ones dealt with in the past, the proposed system has a knowledge base of facts acquired in the systems modelling. The facts in knowledge base are the causal relations in systems and the mathematical equations defined on variables.

An operation test is given to examine the validity and applicability of the proposed system. Moreover, a system dynamics model for maritime industries is presented.

## 2. SYSTEM IDENTIFICATION

The first phase in system dynamics modelling is the problem definition which defines a model purpose, system boundary, and level of concepts elements of a system) aggregation (Andersen 1980, Forrester 1980, Starr 1980, Roberts 1983). This phase is critically important; however, it is close to being an art. In the following, the subsequent phases after the problem definition are investigated.

### 2.1. Extracting Causal Relations

After the problem definition, there lies the phase of system conceptualization which involves, for example, listing the concepts of a system, extracting the causal relations between them, and identifying the feedback structures in conjunction with time delays. "System dynamics deals with change" (Forrester 1980). Any change is induced by some action (including phenomena). Therefore, in this study, the system conceptualization is pursued by perceiving action/decision making and by inferring the causal relations between them. The concepts extracted from a system are expected to be measurable or potentially measurable.

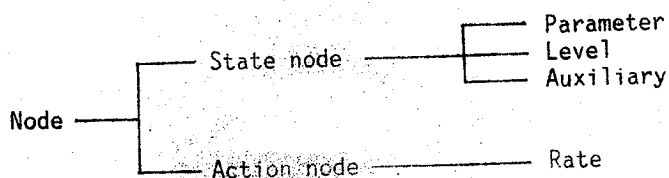

Figure 2 Classification of nodes

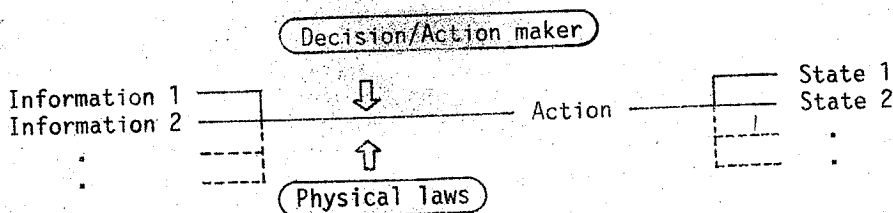

Figure 3 Process of action making

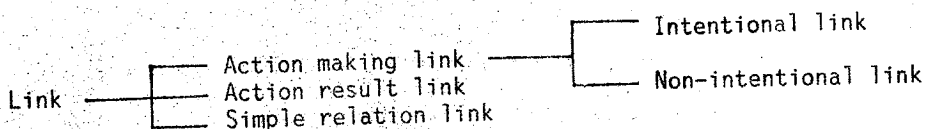

Figure 4 Classification of links

In the system conceptualization phase, a causal-loop diagram is to be prepared. The concept of a system and the causal relation between concepts correspond to the node and the link in the diagram, respectively. The nodes (concepts) can be classified into "action" or "state" node. Figure 2 shows the relationship among the nodes and the variables in system dynamics models. The process of action making is expressed schematically in Figure 3. Action occurs owing to some information/input, and the action changes the state of the object. The action making process is considered as a fundamental unit of causal relations in systems. The links between nodes can be classified into,

so to call it, "action making", "action resulting", or "simple relation (i.e. irrelevant to action making)" link, and further, the action making links are classified into "intentional" or "non-intentional" link (see Figure 4). The whole structure of a system is depicted by selecting the action making units and by interconnecting them directly or through the simple links among them. The process for selecting action making units is, for example, as follows: i) extract the action making unit with explicit decision maker, ii) do that with explicit action maker, iii) do that without explicit decision and action makers (i.e. phenomenon).

It can be said that there is a great variety of data structures to represent causal relations (Nolan 1986). In this paper, the data structures of action, state, and information nodes are given in the form of predicate logic formula (Chang 1973) as follows:

$$\text{Action(AN, OBJ, AM, DM, SYS)} \quad (1)$$

$$\text{State(SN, SBJ)} \quad (2)$$

$$\text{Inform(IN)} \quad (3)$$

where AN is the name of an action, OBJ the object of the action, AM/DM the action/decision maker of the action, SYS the (sub-)system which contains the action. SN is the name of a state, SBJ the subject (substance) of the state, and IN the name of information. "AN" and "SYS" are employed as keywords to retrieve the information about causal relations from a knowledge base (library/catalogue) of dynamic structures of systems (see 2.3.). The data structure to represent a link between nodes is:

$$\text{Link(INN, TNN, LK, SIGN)} \quad (4)$$

where INN is the name of the initial node, TNN the name of the terminal node, LK the kind of the link (see Figure 4), and SIGN the sign of the effect of INN on TNN (positive or negative). It matters little if there are null inputs to AM, DM, SYS in Eq. (1), LK, SIGN in Eq. (2).

In the next place, extraction of causal relations in the upper stream of the information nodes is pursued. The algorithm for extracting the causal relations is shown in Figure 5.

After the extraction of causal relations, all the information

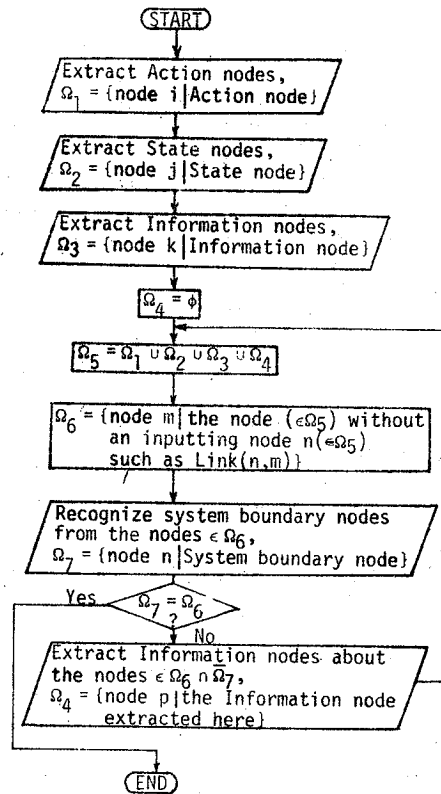

Figure 5 Algorithm for extracting causal relations

nodes are classified into action or state nodes, giving null input to SBJ for the state nodes not influenced by action nodes directly.

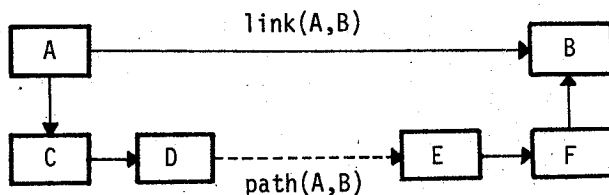

Figure 6 Link and path

Interconnecting the causal relations obtained above, the causal-loop diagram is prepared. The process can be automated by using PROLOG or LISP, because those programming languages have such a function inherently. In causal-loop diagrams, the links between the nodes related indirectly should be eliminated, otherwise the number of links will increase, resulting in a complicated diagram. Some of the knowledge required for eliminating such inappropriate links are represented as the following heuristic rules (see Figure 6).

Rule 1: If Link(A,B,\_,\_),  
 and Path(A,B),  
 and Action(A,\_,\_,\_),  
 and Action(B,\_,\_,\_),  
 and Path(A,B) does not contain Action node except A and B,  
 then Link(A,B,\_,\_) is eliminated. (5)

Rule 2: If Link(A,B,\_,\_),  
 and Path(A,B),  
 and State(A,\_),  
 and Action(B,\_,\_,\_),  
 and Path(A,B) does not contain Action node except B,  
 then Link(A,B,\_,\_) is eliminated. (6)

Rule 3: If Link(A,B,\_,\_),  
 and Path(A,B),  
 and State(A,\_),  
 and State(B,\_),  
 and Path(A,B) does not contain Action node,  
 then Link(A,B,\_,\_) is eliminated. (7)

Rule 4: If Link(A,B,\_,\_),  
 and Path(A,B),  
 and Action(A,OBJa,\_,\_,\_),  
 and State(B,SBJb),  
 and OBJa is not SBJb,  
 and Path(A,B) does not contain Action node except A,  
 then Link(A,B,\_,\_) is eliminated. (8)

where, Path(A, B) is a sequence of links (excluding Link(A,B)), and the each link in the path is directed toward node B and away from node A. Those rules, of course, are not absolute; however, the causal-loop diagram resulting from applying these rules illustrates a clearcut structure of the system. In order to seize the whole structure of the system and the detailed structures of the

sub-systems, it is required to divide the causal-loop diagram into parts according to the action node (see Figure 11, for reference).

## 2.2. Developing Computer Model

In developing a computer model to simulate the system behaviour, it is generally helpful to prepare a flow-diagram by refining the causal-loop diagram. The flow-diagram provides additional insight into the system structure. The necessary step in refining the causal-loop diagram into the flow diagram is the identification of system levels, rates, auxiliaries, and parameters ( in this paper, "parameter" means the system boundary node ). The knowledge required for identifying system levels, rates, etc. is represented as the following rules.

Rule 5: If Action(A,\_,\_,\_),  
then Node A is Rate. (9)

Rule 6: If Link(A,B,\_,\_) does not exist,  
and Node B is not Rate,  
then Node B is Parameter. (10)

Rule 7: If Link(A,B,\_,\_),  
and Action(A,OBJa,\_,\_),  
and State(B,SBJb),  
and OBJa is SBJb,  
then Node B is Level. (11)

Rule 8: If Node A is not Parameter,  
and State(A,\_),  
and Node A is not Level,  
then Node A is Auxiliary. (12)

The computer model is developed by formulating the flow-diagram. In the following, the process of generating a computer program is described:

- 1) Create an abbreviated name for each variable (node) provided that one-to-one correspondence is found between them.
- 2) Write the equation for each variable as a function of the variables in the upper stream. Because of its conventional/standardized format, the rate-level equation is automatically generated referring to "SIGN" (positive or negative) in Eq. (4). As for parameters, each of them is expressed as a function of time. The equations are represented following a computer language statement, e.g. BASIC.
- 3) Save these equations into a file.
- 4) Specify the initial value of each system level. They are expressed in the form of equalities.
- 5) Save these initial values into a file.
- 6) Merge the equation file with the initial value file, and complete a computer program adjusting properly.

## 2.3. Organizing Acquired Knowledge

In order to facilitate future modelling work about a system related to the ones dealt with in the past, the knowledge acquired in the systems modelling should be accumulated in a knowledge base. The facts to be stored in the knowledge base are the causal relations in systems and the mathematical equations defined on variables. The knowledge base is considered as a library/catalogue of dynamic structures of systems (Forrester 1980, Andersen 1980). The facts about action, state, and information nodes are codified according to some indexes. The data structures of the stored facts are given as follows:

Action(AN, OBJ, AM, DM, [SYS], [IN], [SN], [EQ]) (13)

State(SN, SBJ, [AN], [EQ]) (14)

Inform(IN, [AN]) (15)

where [ \* ] is a list, one of the symbolic expression, that means a set of atoms (i.e. arbitrary characters) (Chang 1973, Clocksin 1983), and EQ is the equation for the node defined in the phase of developing computer model. In addition, the facts about links are stored: the data structure follows Eq. (4). In the phase of extracting causal relations, "AN" and "SYS" are employed as keywords to retrieve the information from the knowledge base.

### 3. STRUCTURE OF THE PROPOSED SYSTEM

Fundamental specifications for the expert system of system dynamics modelling are:

- 1) The proposed system is intended for the users without/with technical knowledge about system dynamics modelling.
- 2) Initially, the system has the rules and knowledge only about system dynamics modelling procedure.
- 3) Knowledge/facts acquired in systems modelling are accumulated to facilitate future modelling work.

A skeleton of the expert system is shown in Figure 7. The system is composed of:

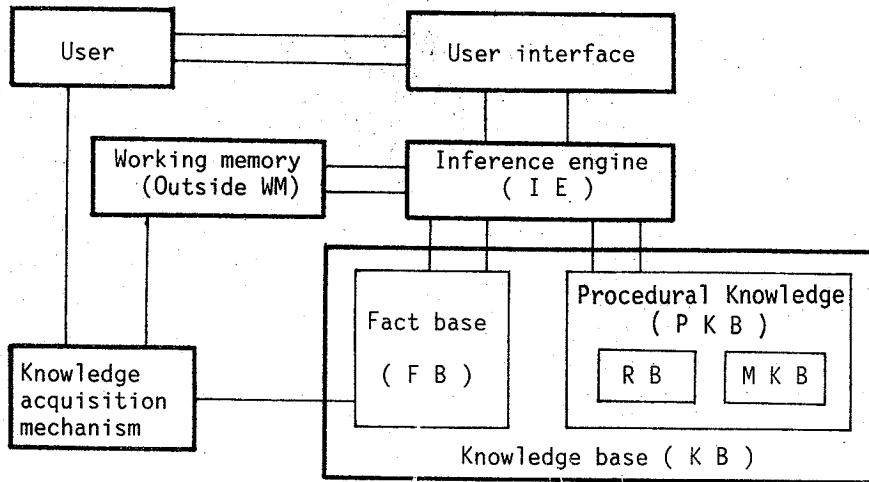

Figure 7 Skeleton of the expert system

- a) Knowledge Base (KB) - This contains the heuristic rules and procedure knowledge about system dynamics modelling and the facts acquired in systems modelling in the past. The rules and procedure knowledge are stored in Procedure Knowledge Base (PKB), and the facts are stored in

- Fact Base (FB).
- b) Fact Base (FB) - The facts about causal relations in systems and mathematical equations of variables are stored. The data structures of the facts are given by Eqs. (4), (13)-(15).
  - c) Procedure Knowledge Base (PKB) - The rules to operate the facts are stored in Rule Base (RB). The procedure knowledge about system dynamics modelling are stored in Meta-Knowledge Base (MKB). PKB is the core program of the system encoded in PROLOG.
  - d) Rule Base (RB) - The rules, that would be applied to the facts, are stored. Each rule has a precondition, and it can be applied if the precondition is satisfied. Such rules are called "production rules".
  - e) Meta-Knowledge Base (MKB) - The procedure knowledge about system dynamics modelling, including the meta-knowledge/meta-rules, i.e. knowledge/rules about how to use other knowledge/rules, are stored.
  - f) Inference Engine (IE) - This draws new conclusions from given facts applying the rules and procedure knowledge which are loaded from PKB at the system starting. In addition, the facts in FB are provided to IE according to demand. Facts are operated and stored in Inside Working Memory (Inside WM). In this system, PROLOG interpreter plays the role of IE (see Figure 8).
  - g) Working Memory (WM) - This is a storage area used for the facts and other short-term information. In this system, because of the limitation of the memory capacity, Outside WM is equipped using an external memory device in addition to the Inside WM of IE.
  - h) Knowledge Acquisition Mechanism - This extracts the knowledge about causal relations in systems from the facts in WM, and codifys them to be stored in FB. Sometimes the knowledge is directly imputed by the user.

Both Inference Engine and the proposed system are based on "production system" (Nilsson 1980, Forsyth 1986).

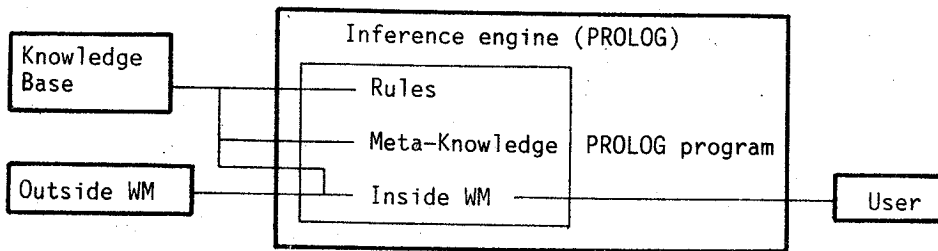

Figure 8 Structure of inference engine

Using the rules and procedure knowledge described in chapter 2, the expert system generates a system dynamics model. Figure 9 shows the flow of the system procedure. To facilitate writing equations in the phase of formulating causal relations, the proposed system supports some built-in functions such as TABLE, PULSE, etc. in DYNAMO.



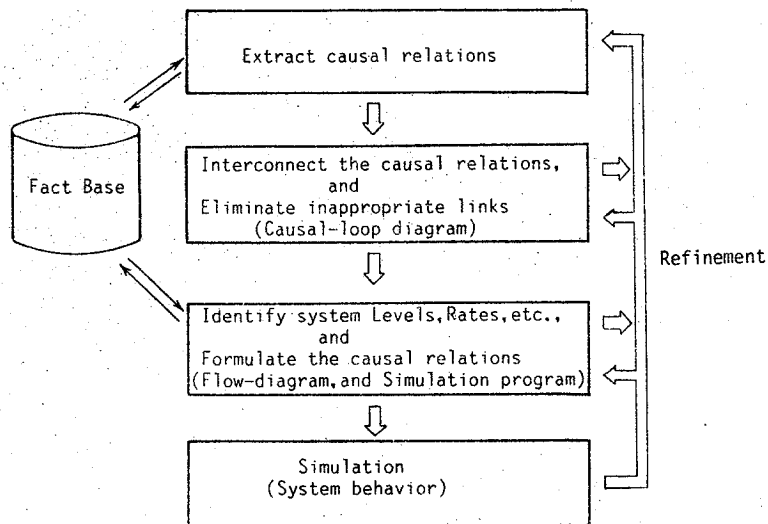

Figure 9 Flow of the system procedure

#### 4. APPLICATION EXAMPLES

In this chapter, the following application examples are provided to verify the applicability of the proposed system.

##### 4.1. Operation Test

An operation test is given to examine the validity and applicability of the proposed system. Three model builders (i.e. Mr. A: a student without knowledge about system dynamics, Mr. B: a student with a little knowledge about system dynamics, but he is inexperienced in this expert system, and Mr. C: one of the authors) get the following exercise.

##### Exercise : Ecosystem of an island

Suppose an island on where hare and fox are inhabiting. an ecosystem of the island is as follows:

Hare feed on grass, and fox prey upon hare. The number of their natural births/deaths depends on their population. The number of hare killed by fox depends on both the fox population and the number of hare killed per fox. The number of hare killed per fox depends on the hare population density. The food scarcity affects the population deeply. The number of deaths by starvation depends on the shortage of their food supply. The growth potential of grassland is proportional to the area; however, the grassland area is decreased by hare, and the size of the area decreased depends on the hare population. Of course, there is an upper bound of the grassland area owing to the limited land.

It is known that the island has a large amount of deposits underground. The digging of the deposits decrease directly the area of the grassland, i.e. hare's habitat. Furthermore, pollution caused by the digging will lower the

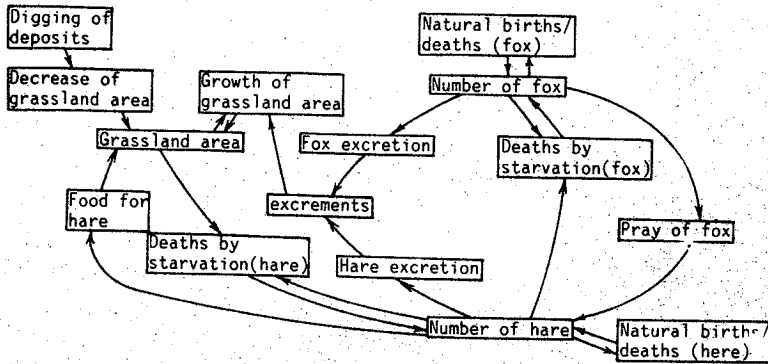

(a) Model A: Causal-loop diagram prepared by Mr.A

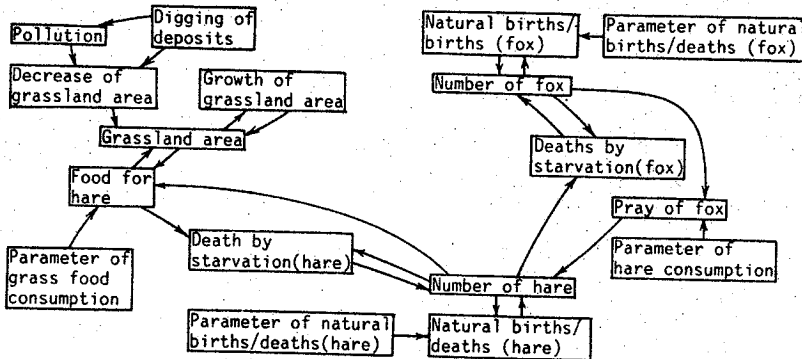

(b) Model B prepared by Mr.B

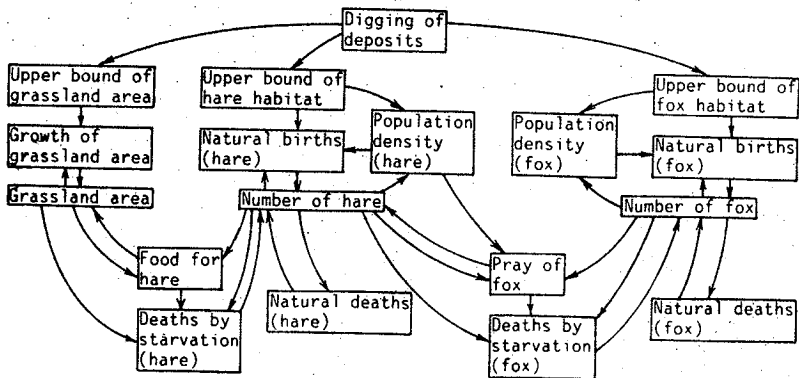

(c) Model C prepared by Mr.C

Figure 10 Causal-loop diagrams for an ecosystem

```

*****
* Causal Links (Sub-System) *
*****

##### SUB-SYSTEM[1] #####
NODE = digging_of_deposits
NODE = upper_bound_of_grassland_area
NODE = upper_bound_of_hare_habitat
NODE = upper_bound_of_fox_habitat

LINK = digging_of_deposits -> upper_bound_of_grassland_area
LINK = digging_of_deposits -> upper_bound_of_hare_habitat
LINK = digging_of_deposits -> upper_bound_of_fox_habitat

##### SUB-SYSTEM[2] #####
NODE = natural_births_hare

*****
* Causal Links (Total-System) *
*****
NODE = SUB-SYSTEM[1]
NODE = SUB-SYSTEM[2]
NODE = SUB-SYSTEM[3]
NODE = SUB-SYSTEM[4]

LINK = SUB-SYSTEM[2](NODE=18) -> SUB-SYSTEM[3](NODE= 11)
LINK = SUB-SYSTEM[2](NODE= 4) -> SUB-SYSTEM[3](NODE= 11)
LINK = SUB-SYSTEM[4](NO
LINK = SUB-SYSTEM[2](NO
LINK = SUB-SYSTEM[2](NO
LINK = SUB-SYSTEM[2](NO
LINK = SUB-SYSTEM[3](NO
LINK = SUB-SYSTEM[1](NO
LINK = SUB-SYSTEM[1](NO
LINK = SUB-SYSTEM[1](NO

*****
* Paths between Sub-Systems *
*****
PATH = SUB-SYSTEM [1]---->SUB-SYSTEM [3]
(1)upper_bound_of_grassland_area---->(16)growth_of_grassland
PATH = SUB-SYSTEM [1]---->SUB-SYSTEM [2]
(2)upper_bound_of_hare_habitat---->(18)population_density_hare

*****
* Sub-Systems and Nodes *
*****

##### SUB-SYSTEM [1] #####
7---digging_of_deposits
1---upper_bound_of_grassland_area
2---upper_bound_of_hare_habitat
3---upper_bound_of_fox_habitat

##### SUB-SYSTEM [2] #####
8---natural_births_hare
4---number_of_hare
9---natural_deaths_hare
10---deaths_by_starvation_hare
15---pray_of_fox
18---population_density_hare

##### SUB-SYSTEM [3] #####
11---food_for_hare
5---grassland_area
16---growth_of_grassland

SUB-SYSTEM [4]
17)population_density_fox

SUB-SYSTEM [3].
11)food_for_hare

SUB-SYSTEM [4]
14)deaths_by_starvation_fox

SUB-SYSTEM [2]
10)deaths_by_starvation_hare

SUB-SYSTEM [2]
5)pray_of_fox

SUB-SYSTEM [3]
_hare---->(11)food_for_hare

```

Figure 11 Example of the system's output (model C)

growth potential of the grassland.

Develop an ecosystem model of the island to examine the effect of the digging of deposits.

Modelling of the ecosystem structure is carried out using the proposed system. Figure 10 shows the results illustrating the system's output with causal-loop diagrams. Though model A and model B are fairly analogous, there are many difference in the three models with regard to the level of the problem recognition. However, the each model succeeded in extracting the same critical concepts and feedback loops in the system; so that the proposed system is not altogether worthless. If the model builders enter on the phase of system formulation, then those models will be refined fairly well. It should be praised that Mr. A detected the causal relation about fox and hare's excretions. Figure 11 shows an example of the system's output for model C.

#### 4.2. Modelling of Maritime Industries

On account of complicated international and economical circumstances, shipbuilding and shipping industries in the developed countries are going through their serious recession (Nersesian 1981, Taguchi 1986, Kishi 1986). In order to find suitable steps, it may be appropriate to employ system dynamics models in the policy analysis. In this section, a system dynamics model for maritime industries is presented using the proposed system.

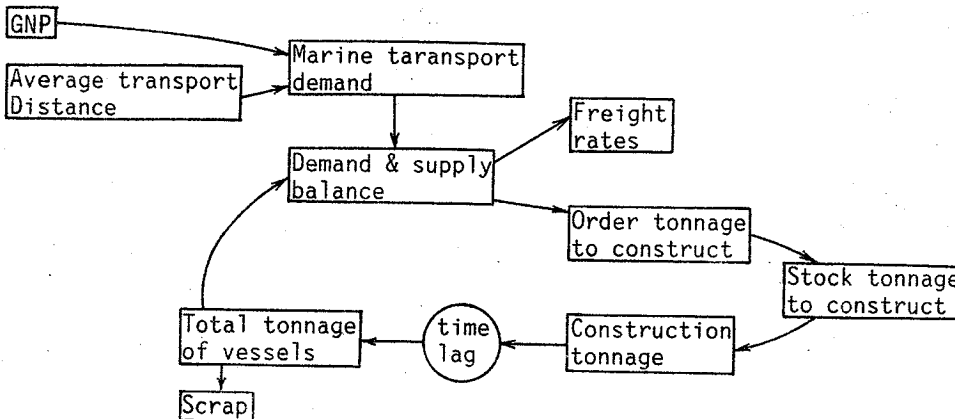
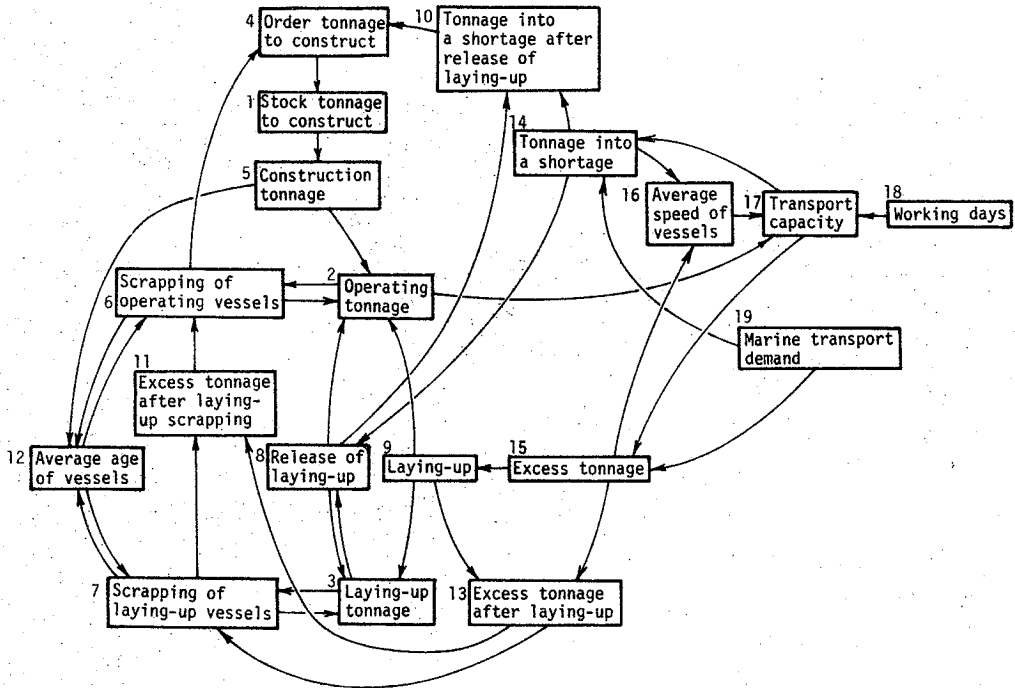

Figure 13 Causal-loop diagram for tanker fleets system (SD Research Society in JMRI 1977)

Extraction of the causal relations of the system are pursued by the authors. Maritime industries are composed of shipping, shipbuilding, and port & harbour. And further, for example, shipping is divided into specialized markets (tanker, bulker, container, etc.) (Nersesian 1981). Figure 12 shows a causal-loop diagram for the tanker fleets system obtained using the proposed system, and the identified system levels, rates, etc. Japan Maritime Research Institute has already provided a similar model as shown in



\*\*\*\*\* LEVELS \*\*\*\*\*

Node No. --- 1  
Node Name --- stock\_tonnage\_to\_construct  
subject ---- ship

Node No. --- 2  
Node Name --- operating\_tonnage  
Subject ---- ship

Node No. --- 3  
Node Name --- laying\_up\_tonnage  
Subject ---- ship

\*\*\*\*\* RATES \*\*\*\*\*

Node No. --- 4  
Node Name --- order\_tonnage\_to\_construct  
Object ---- ship

Node No. --- 5  
Node Name --- construction\_tonnage  
Object ---- ship

Node No. --- 6  
Node Name --- scrapping\_of\_operating\_vessels  
Object ---- ship

Node No. --- 7  
Node Name --- scrapping\_of\_laying\_up\_vessels  
Object ---- ship

Node No. --- 8  
Node Name --- release\_of\_laying\_up  
Object ---- ship

Node No. --- 9  
Node Name --- laying\_up  
Object ---- ship

\*\*\*\*\* AUXILIARIES \*\*\*\*\*

Node No. --- 10  
Node Name --- tonnage\_into\_a\_shortage\_after\_release\_of\_laying\_up

Node No. --- 11  
Node Name --- excess\_tonnage\_after\_laying\_up\_scrapping

\*\*\*\*\* PARAMETERS \*\*\*\*\*

Node No. --- 18  
Node Name --- working\_days

Node No. --- 19  
Node Name --- marine\_transport\_demand

Figure 12 Causal-loop diagram for tanker fleets system

Figure 13 (SD Research Society in JMRI 1977). Although the two models differ in their elaborateness, the central structures of the causal relations in the models are equivalent. Behaviour of the each model is simulated, and the results are shown in Figure 14 for reference.

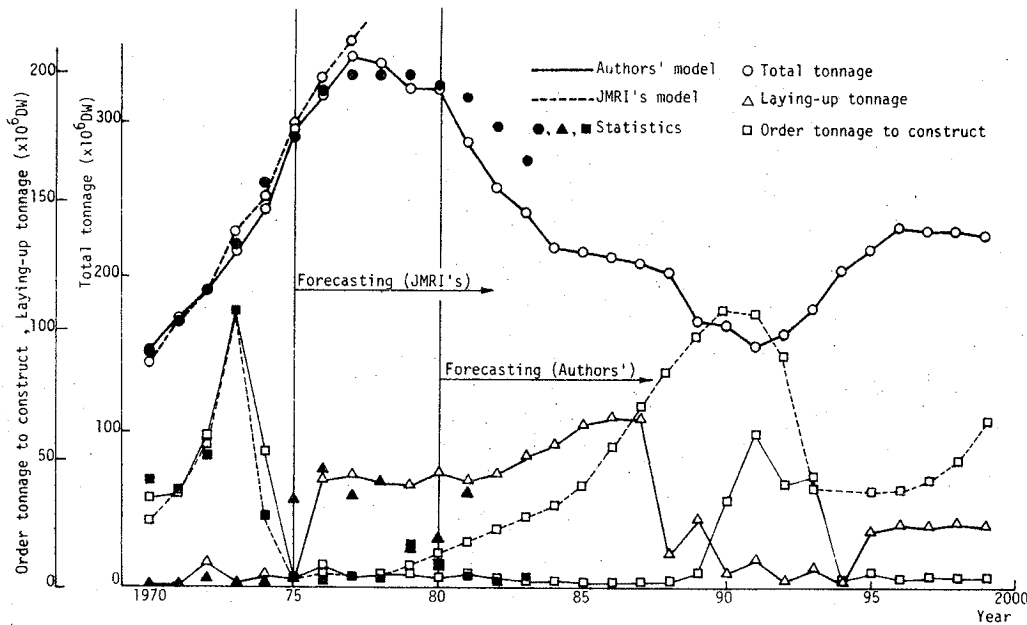

Figure 14 System behaviour

## 5. CONCLUSIONS

This paper is concerned with an expert system to support system dynamics modelling. The application examples are provided to verify the applicability of the proposed system. The results are summarized as follows:

- 1) The process for system dynamics modelling is investigated. Some rules and procedure knowledge for preparing system dynamics models are presented, and the data structures of causal relations are given in the form of predicate logic formula.
- 2) An expert system for system dynamics modelling is designed including the knowledge base about causal relations.
- 3) The results of the application examples are in the following: i) The proposed system effectively supports the system dynamics modelling not only by the user with little technical knowledge about system dynamics but also by experienced user. ii) In eliminating inappropriate links in the causal-loop diagrams for large systems, the proposed system needs some heuristic rules to avoid the problem of infinite number of path combinations.

## REFERENCES

- Andersen D.F., and Richardson, G.P. (1980), "Toward a Pedagogy of System Dynamics", TIMS Studies in the Management Science, No. 14, North-Holland, pp 91-106
- Axelrod R.(ed.) (1976), Structure of Decision: The Cognitive Maps on Political Elites, Princeton University Press.
- Chang, C.L., Lee, R.C. (1973), Symbolic Logic and Mechanical Theorem Proving, Academic Press.
- Clocksins, W.F., and Mellish, C.S. (1983), Programming in Prolog, Springer-Verlag.
- Elzas, M.S., Oren, T.I., and Zeigler, B.P. (eds.) (1986), Modelling and Simulation Methodology in the Artificial Intelligence Era, North-Holland.
- Forrester, J.W. (1961), Industrial Dynamics, MIT Press.
- Forrester, J.W. (1980), "System Dynamics - Future Opportunities", TIMS Studies in the Management Science, No. 14, North-Holland, pp 7-21
- Forsyth, R., and RADA, R. (1986), Machine Learning: Applications in Expert Systems and Information Retrieval, John Wiley & Sons.
- Kishi, M., Nakayasu, H., Noda, K., and Taguchi, K. (1986), "Cognitive Map and System Analysis of Maritime Industry", in: Hubner, H. (ed.), The Art and Science of Innovation Management, Elsevier Science, pp 385-399
- Nersesian, R.L. (1981), Ships and Shipping: A Comprehensive Guide, Penn Well.
- Nilsson, N.J. (1980), Principles of Artificial Intelligence, Springer-Verlag.
- Nolan, P.J., and McCarthy, M.A. (1986), "AI Frame-Based Simulation in System Dynamics", in: Sriram D., and Adey R. (eds.), Applications of Artificial Intelligence in Engineering Problems, Vol. 1, Springer-Verlag, pp 527-538
- Pugh, A.L. (1976), DYNAMO User's Manual, Fifth Edition, MIT Press.
- Roberts, N., Andersen, D.F., Deal, R.M., Garet, M.S., and Shaffer, W.A. (1983), Introduction to Computer Simulation; A System Dynamics Modeling Approach, Addison-Wesley.
- SD Research Society in JMRI (1977), "SD Model for Shipping and Shipbuilding - Tanker Market" (in Japanese), Journal of the Japan Maritime Research Institute, No. 130, pp 5-21
- Starr, P.J. (1980), "Modeling Issues and Decisions in System Dynamics", TIMS Studies in the Management Science, No. 14, North-Holland, pp 45-59
- Taguchi, K., Kishi, M., Nishimura, M., Nakayasu, H., and Hasegawa, N. (1986), "Normative Forecasting Model for Promoting National Shipping", Proc. of 3rd Latin-Ibero American Congress on Operations Research and Systems Engineering.