

# Parameter Estimation in System Dynamics Model by Multi-Optimization Technique

Tohru Higuchi  
Department of Economics  
University of Surugadai  
Azu, Han-nou, Saitama, JAPAN

## Abs tract

In this study we tried to estimate unknown parameters in a System Dynamics Model by optimization technique instead of trial and error.

As the number of unknown parameters increases, it is difficult to estimate them by trial and error because the number of combinations of them increases rapidly. It follows that model builders are often forced to identify them subjectively. That's a weak point of System Dynamics Models - lack of model validation.

We had tried to optimize controllable parameters on the basis of some objective functions. (2)(3) We applied this parameter optimization technique to parameter estimation. The unknown parameters were estimated by using observational data as econometricians usually do in especially simultaneous decision models.

A simplified Inventory Control Model which includes two unknown parameters is used in this study.

## Introduction

Consider the System Dynamics Model described by the following form.

$$df(x,t)/dt = f(x, p, c) \quad (t_0 \leq t \leq t_1)$$

where  $f$ ,  $x$ ,  $p$ , and  $c$  is respectively function, variable, unknown parameter, and constant vector. Let's regard known parameters, if any as members of a constant vector for now. Suppose we got observed time series data from  $t=t_0$  to  $t=t_1$ , denoted by  $x^*(t)$ . A criterion function denoted by  $e(p)$  is defined as follows.

$$e(p) = \sum_i w_i \int_{t_0}^{t_1} (x^*(t) - x(t))_i^2 dt \quad , \quad \sum_i w_i = 1$$

where  $x(t)$  and  $w_i$  denotes respectively, variable vector generated by the System Dynamics Model and a weight for simplification of criteria, in which  $i$  designates each element of variable vector selected as a criterion.

We can estimate unknown parameters by solving following problem:

$$\min_p e(p) \quad , \quad p \in P_c$$

where  $P_c$  denotes admissible space for the parameters.

Because  $e(p)$  can't be expressed as analytic function of  $p$  and therefore its derivative  $de/dp$  can't be evaluated, gradient methods aren't applicable to this problem. So we used simplex method, which is one of direct search methods.

### Simplified Inventory Model

This Inventory Model has been derived from the Water Pond Model<sup>(1)</sup>.

Production, distribution and consumption in this model corresponds to water flow into or out of ponds in the original model, and inventory at retailer and distributor corresponds to water stored in each pond in the original one. (Fig1)

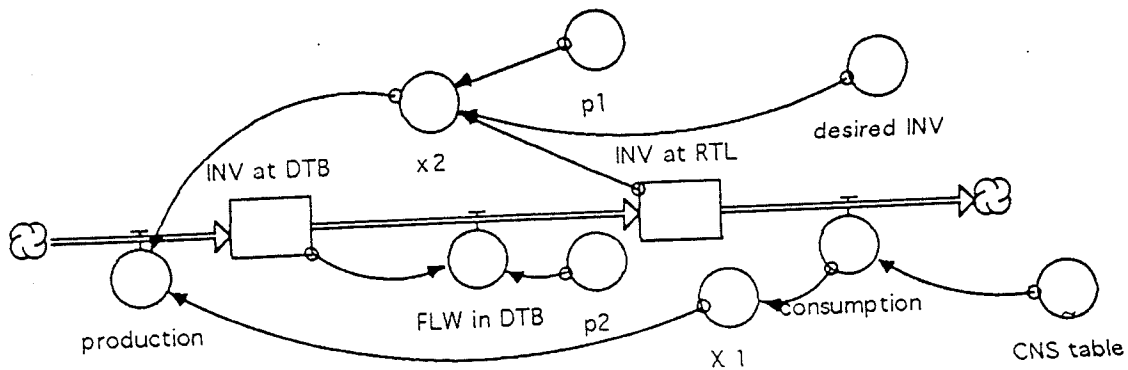

Fig 1 Inventory Model

In this tentative study we used the generated data added normal random numbers instead of real (observed) data.

Next we give a summary of dynamic mechanism of his model which are production flow rate and distribution flow rate.

(1) Production Flow Rate: the smoothed value of consumption denoted by  $x_1$  added (subtracted) adjustment to stabilize inventory at retailer denoted by  $x_2$ .

One of unknown parameters is the a certain fraction of difference an actual and a desired inventory level at retailer, denoted by  $p_1$ .

(2) Distribution Flow Rate: the delayed value of inventory at distributor.

The other unknown parameter is a certain fraction of an actual inventory level at distributor, denoted by  $p_2$ .

Now let's introduce a criterion function;

$$e(p_1, p_2) = w_1 \int_{t_0}^{t_1} (x_1^* - x_1)^2 dt + w_2 \int_{t_0}^{t_1} (x_2^* - x_2)^2 dt$$

In this model we supposed only  $x_1$  and  $x_2$  are observable. Suppose weights and term are as follows,

$$w_1 = 0.8 \quad , \quad w_2 = 0.2 \quad , \quad t_0 = 0 \quad , \quad t_1 = 25$$

Therefore  $e(p_1, p_2)$  is expressed in the more concrete form, as follows,

$$e(p_1, p_2) = \int_0^{25} \{ 0.8 (x_1^* - x_1)^2 + 0.2 (x_2^* - x_2)^2 \} dt$$

### Parameter Search Process

At first this model was described in STELLA and then it was rewritten in BASIC and combined into Search Program in BASIC where one running of simulation process evaluates a function  $e(p)$ .

Now we give an outline of simplex method. (See (4))

When the number of dimension of parameter space is  $n$ ,  $n+1$  points form a simplex in the space. The worst point, that maximizes a criterion function should be moved to a better point in the direction which is found by using best two points. Iterating this process, the simplex will converge nearly on minimum point. Let's explain our model in more detail. Circles in Fig2 present contour lines of a pond where  $e^0$  is the deepest point (destination). Given an initial simplex  $p^1 p^2 p^3$  at random, simulation process runs on each point. The shallowest point  $p^1$  should be moved. To get a preferable direction, the reflected point of  $p^1$  on  $p^2 p^3$  denoted by  $p^r$  is calculated and then a better point is tried in the direction, which may be  $p^e$  (extended point),  $p^c$  (contracted point) or  $p^r$  (reflected point). In this case next simplex seems to be  $p^r p^2 p^3$ . See Fig2. Failed to find a better point on the simplex, it is reduced around the deepest point  $p^3$  keeping similar figures, that is simplex  $p^{1'} p^{2'} p^3$ . A condition of terminating the iteration is as follows,

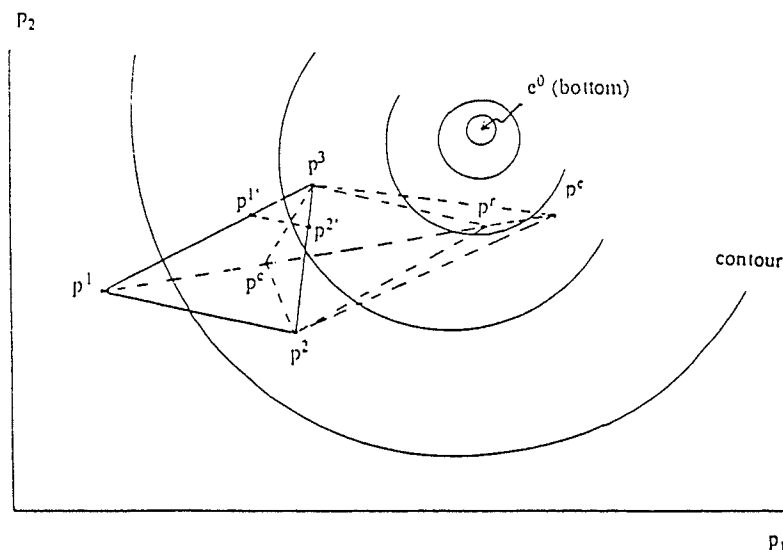

Fig2 Simplex and Contour Line of e(Square Error Function)

$$\sqrt{\{e(p^i) - e(p^0)\}^2} \leq \text{eps}$$

where  $p^0$  is a center of gravity in a simplex and eps is permissible limit, now let's  $\text{eps}=10^{-5}$

### conclusion

starting with initial value of  $p$  ( $p = (0.1, 1.0)$ ), simplex converged on  $p = (0.188, 3.847)$  after 29 iterations. All twenty different initial values of  $p(0 \sim 1.0, 0 \sim 20)$  converged nearly on this point. At a conservative estimate within the range of  $p$  shown above we succeeded in estimating unknown parameters. We also tried to figure out values of 2500 mesh points ranging from  $(p_1, p_2) = (0.0, 1.0)$  to  $(2.0, 10.0)$ . Fig3 shows 3 dimensional graph with horizontal-axes for  $p_1$  and  $p_2$ , and vertical-axis for  $e(p_1, p_2)$  shown upside down. You can see a bottom near point  $(0.188, 3.85)$  on horizontal plane in Fig3.

We think of applying this study to identification of human (mental) models.

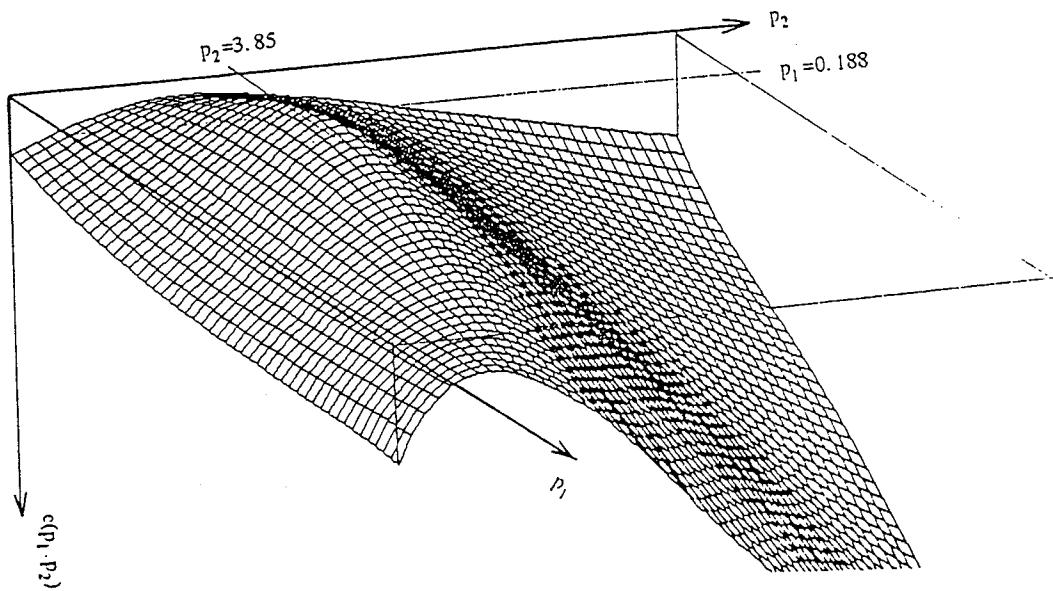

Fig3 3 Dimensional Graph of  $e$  (Square Error Function)

### References

- (1) Shimada, T ed. 1994. An Introduction to System Dynamics (Japanese). Nikka-Giren Tokyo, Japan
- (2) Higuchi, T. 1981. An Sensitivity Analysis of Parameters in Dynamic Models (Japanese). Syogaku-Tohkyu 32(2)
- (3) Higuchi, T. 1982. On Multi-Optimization of a Social System Model (Japanese). Syogaku-Tohkyu 33(2/3)
- (4) S.L.S. Jacoby et. 1972. Iterative Methods for Nonlinear Optimization Problems Prentice-Hall